

Automated Garbage Disposal System

T Pratheek Reddy¹ | Prof. Saurabh Gautam²

¹ UG student, IT & Maharaja Agrasen Institute Of Technology, Dehi, India

² Asst. Prof. Department of IT & Maharaja Agrasen Institute Of Technology, Dehi, India

To Cite this Article

T Pratheek Reddy, Prof. Saurabh Gautam, "Automated Garbage Disposal System", *International Journal for Modern Trends in Science and Technology*, 6(12): 108-112, 2020.

Article Info

Received on 06-November-2020, Revised on 25-November-2020, Accepted on 29-November-2020, Published on 02-December-2020.

ABSTRACT

Our project mainly focuses on providing a better method and a model to help the government or any local authorities at managing their waste disposal management. In this model we use an ultrasonic sensor with the use of an arduino board to measure the level of garbage waste in trash cans. The sensor measures the distance from the top and determines the capacity to which the bin has been filled, then we use a software twillio to send a SMS to the respective authorities. It therefore provides a real-time indication of the quantity of garbage. Therefore all the components of the system work in an intelligent and a coherent manner so that waste is collected on time and we can keep our surroundings clean.

KEYWORDS: Automated garbage disposal, Ultrasonic sensor, Sonar, Twillio Sms.

I. INTRODUCTION

As India has a population of 1.3 billion, the second highest in the world. With a population this big also comes the problem of the disposal of the large quantities of waste generated everyday. One only needs to go out of his/her house to see how bad the garbage disposal system in our country is and to our dismay it shows no promise of getting better. So my statement problem is to create an automated garbage disposal system, which would help in regulating the garbage on the streets of India. I choose this topic as a social concern for all of us. From the spread of the corona virus and since the quarantine started people have realised the importance of being neat and having a clean environment. The overflowing of garbage is a sanitary issue anywhere and I hope that this project can aid in India becoming a better and clean country. Our objective is to create a system of garbage disposal using IOT which sends a message to respective authorities indicating that the trash is full and needs to be cleared. What our system does

is it gives a real time indication of the garbage level in a trash can at any given time.

II. RELATED WORK

1. Automatic Garbage Disposal System

Authors:

Viduranga Wijesooriya

University of Moratuwa

K.A.K.N.D. Dharmapala

Chinthaka Chandrasekara

U.K.A.U. Rathnapriya

Received: August 2012

DOI: 10.13140/RG.2.2.12124.18566/1

Thesis for: B.Sc. (Hons) in Information

Technology Advisor: D.K. Withanage

This project mainly focuses on offering an easy and a reliable solution to the problem of inefficient garbage disposal faced within schools, which also implies that the main end user of this product would be school authorities. In this project we have decided to implement a remote control, fully automated, line following garbage bin. In this

system, there are two main devices. A remote controlled device equipped with a real time clock which sets the start time and then compares it with the real time and alerts the garbage collection process via radio signal. Then the garbage collector, starts its process after receiving the signal from the remote controller device. The process includes the garbage collector to stop at all the classrooms one at a time and collect the garbage till the garbage collector becomes full , it follows a marked black line using the infrared sensor to all the places . When the garbage becomes full it is taken straight to the dumping site without any break at any other places . If we look at it closely it has 3 main components which are the remote controller device , the garbage collector and the garbage container . Microcontrollers are used in two places 1.In the radio signal to maintain a routine and precise timing for the garbage collector and 2.the IR sensor is used to provide a path for the garbage collector , it follows this path from class to class and to the dumping site ,it helps to maintain a specific path and accuracy at all time.

2.An Automated Waste Control Management System (AWCMS) by Using Arduino

Authors:

Agha Muhammad Furqan Durrani

Ateeq Ur Rehman

Arslan Farooq

Jehangir Arshad

Published in: February 2019

DOI: 10.1109/CEET1.2019.8711844

Conference: 2019 International Conference on Engineering and Emerging Technologies (ICEET)

A project on Automated Waste Control Management System has been compiled which includes an electronic waste detection device and a central control unit. It uses an infrared sensor for measuring the garbage , GPS for location , an arduino board for microcontrollers and a GSM module for sending information regarding the bin . In this model the garbage disposal system sends a message regarding the garbage collected via the GSM module to the central system which is then sent to the computer via a USB cable . In this model the gps gives the precise longitude and latitude of all the bins at all times and whenever we get the information regarding a bin is full the municipal can send its crew to empty the bin via the gps . This helps in providing a cleaner environment for everyone . Therefore, all the components in this system work in an smart manner to make automated waste management possible so that the waste is collected and disposed

to the dumping sites only when it is necessary at a proper time. This work mainly focuses on timely and automatic waste collection and transportation mechanism

These two aspects if executed will accurately, can prove as one of the pivotal factors that smartly utilizes all the resources provided to it.

III. METHODOLOGY

Now days all have busy life for e.g. person staying somewhere for In this section the detailed methodology of how the project was built using an ultrasonic sensor and then a message is sent using the twilio SMS software will be explained.

A. Hardware components

The hardware components used in this project include :

1.BOLT wifi module : BOLT is an internet of things platform Hardware + Software that enables user to build IOT products and projects. Bolt can be used to operate the device from any place.

2.Arduino board : Arduino is an open-source platform used for building electronics projects. Arduino consists of both a physical programmable circuit board and a piece of software, or IDE that runs on your computer, used to write and upload computer code to the physical board.

3.HCSR04 sensor : This sensor is used to measure the distance of the garbage in the bins , it is very famous sensor for measuring and sensing objects . It has a physical appearance of two eyes which act as the transmitter and the receiver .

B. Software requirements

The softwares used in building of this project are :

- Arduino IDE : The Arduino Integrated development environment (IDE) is a cross-platform application (for Windows, mac OS, Linux) that is written in the programming language Java. We use this to write and upload the code of the ultrasonic sensor.

- Twilio : It is a messaging software which is used to send messages to the phone of the person registered . We use this to get the information from the garbage collector.

- VM-WARE : we use this for our own server where we can code in ubuntu regarding the receiving of messages from the sensor.

C. BOLT IOT bolt cloud

The first step will be to link the bolt wifi module with your bolt cloud account .The bolt wifi module

is connected over the bolt hotspot . when you enter the SSID , the name of your network and password is transferred to bolt and stored on it . We need to create a new product for this project on the bolt , you need to configure and code the basic and also need to specify whether the product will be a receiver or a transmitter .

D. Twilio Account

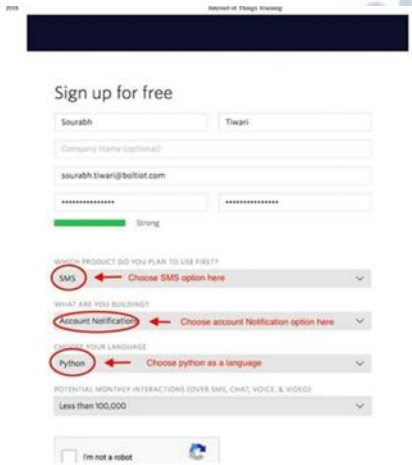

Fig 3.1 Twilio account

Login in the twilio account as above . The phone number you provide will be used for authentication when you login to twilio console . Verify the number given to proceed further. Then create a product in the software and select the programmable sms and phone number option as we need to get a sms . After this necessary information regarding the project has to be given and a new number will be provided with which you can access the account.

E. Schematics

Now the connections for the hardware circuit are as follows

Ultrasonic to arduino connections

- Vcc -> 5V#SUPPLY VOLTAGE TO SENSOR
- Trig -> 12
- Echo -> 13
- GND -> GND

Arduino to bolt wifi module connections

- Rx -> TX#RX->RECIEVER, TX->TRANSMITTER
- Tx -> RX
- GND -> GND
- VIN->5V #SUPPLY VOLTAGE TO BOLT

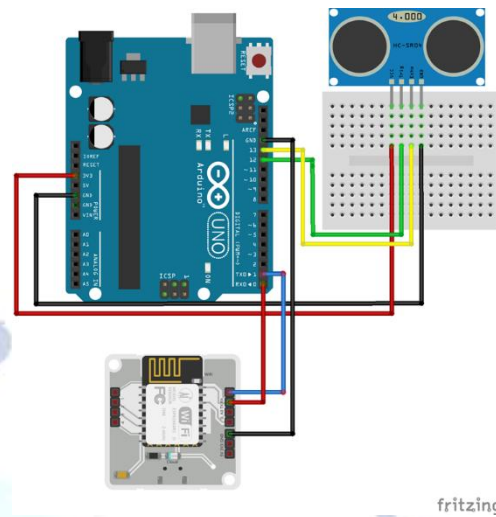

Fig 3.2 Hardware schematic

F. Server side appliance

The server side code is done in python , we read the 13th pin rather than the 12th pin as we use only one value at a time and it is compatible with int base 10. There exists a delay in reading the sensor values and the received values at our end but tis can be corrected by increasing the time in between reading two consecutive sensor readings and lower the time.sleep() of bolt . After this the delay was reduced by a large extent One problem that occurs is that if the objects are brought too close to the sensor it displays an error value of 357and hence we do consider it here. Also if the ports of the sensor in the code are changed then port in command response=mybolt.serialRead('13') also changes else it will read the voltage at the wrong portand that value is transmitted to the bolt rather than distance measured by sensor.

```

from boltiot import Bolt, sms #import sms and Bolt class from boltiot library
import bolt, json, time # accessing the json and time function
Maxlimit= 10 # the distance between device and garbage in dustbin in cm

mybolt = Bolt(bolt.API, bolt.ID) #create object to fetch data
sms = sms(bolt.SID, bolt.AUTH, bolt.TO, bolt.FROM) #Create object to send SMS
response = mybolt.serialRead('13')# we are now receiving the data read at the 13th pin of arduino board
>int(response)

while True:
    response = mybolt.serialRead('13') #fetching the value from Arduino 13th pin
    data = json.loads(response)#storing the value received to the bolt from arduino
    glevel = data['value'].rstrip()#storing the integer part
    print("Garbage level is", glevel)

    if (int(glevel) <= Maxlimit or int(glevel)==357):
        response = sms.send_sms("Hello I am full,please clean me out") #sending the sms to your mobile number
        time.sleep(2.5)#time between two consecutive readings in seconds
    
```

Fig 3.3 server code

G. Bolt API key

This is a python file has all the necessary keys and information for bolt to access the cloud as well as access your twilio account via API

```
API = "bolt cloud api"
ID = "device"

# Credentials required to send SMS
SID = 'your twilio account sid'
AUTH = 'your twilio account auth token'
FROM = 'your twilio number'
TO = 'your number to get alert sms, please dont forget to add your country code in the beginning of your phone number '
# Save it in a separate file called as bolt.py and then we can access this file in the main code by importing it there
```

Fig 3.4 Bolt code

H. Aurdino IDE

The Arduino integrated development environment (IDE) is a cross-platform application (for Windows, mac OS, Linux) that is written in the programming language Java. It is used to write and upload programs to Arduino board. It is an open source software so either visit the Arduino home page and download the software in your system else you can use the link below to guide you in setting up Arduino IDE in your system

```
#include <ultrasonic.h> // library to access the function distance read
Ultrasonic ultrasonic(12, 13); // trig-12, echo-13
void setup() { // setting up the sensor to work
  Serial.begin(9600); // initializing the frequency to run the sensor
}
void loop() { // initializing the loop
  Serial.println(ultrasonic.distanceRead()); // prints the distance measure by the sensor on the serial monitor also transmits these values to the bolt wifi module
  delay(4000); // time taken between two consecutive readings
}
```

Fig 3.5 Aurdino code

IV. FINAL RESULT

Hence here the output will be in form of messages if only when the dustbin limit is lesser than the threshold value we coded in the server code In the below picture we get the message from different numbers

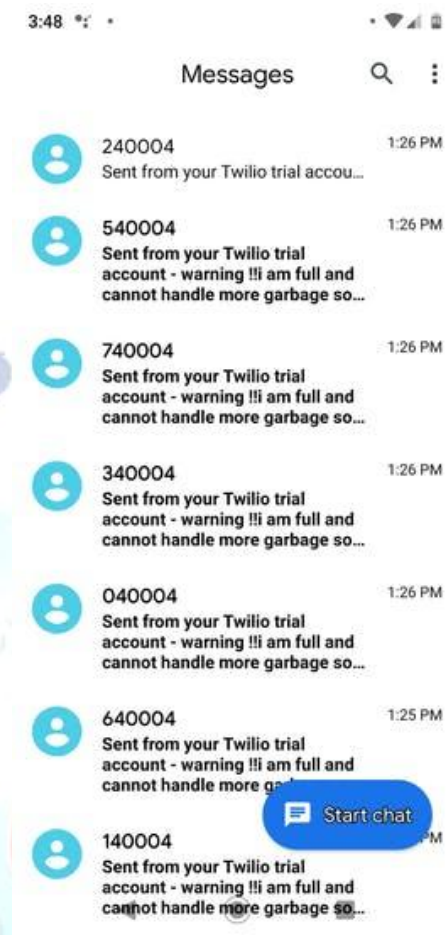

Fig 4.1 Message recieved

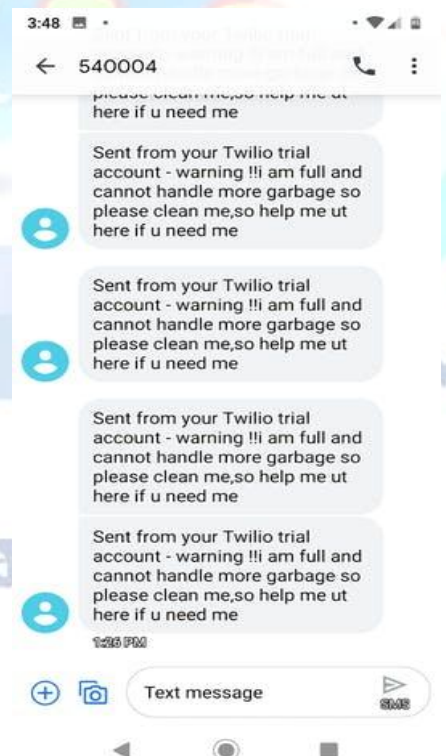

Fig 4.2 Message recieved

V. CONCLUSION

This project provides an efficient garbage monitoring system which can be used to monitor the level of garbage in the bin . This data can be further used to plan garbage collection trips more efficiently , ultimately reducing overflowing bins and helping to have a better public sanitation.

As considering this project motto,the scope of this project is vast as garbage disposal is common to every person in India which has such a vast population and thus a major scope . We see so amny trash bins on the sidewalks everyday overflowing with garbage and this project aims to tackle this problem . This system can be used by offices , colleges , appartment complexes or by the GhMC to keep tabs on the waste disposal system.

ACKNOWLEDGMENT

I thank my Mentor Prof. Saurabh Gautam for analyzing the data and for advising on all aspects related to this paper, along with other concepts too. Later for validating the experimental result and reviewed the paper.

REFERENCES

- [1] I. Oditis and J. Bicevskis, "The concept of automated process control", Comput. Sci. Inf., vol. 2010, no. 756, pp. 193-203.
- [2] E. Adetiba, V.O. Matthews, A.A. Awelewa, I.A. Samuel and J.A. Badejo, "Automatic electrical appliances control panel based on infrared andWi-Fi: A framework for electrical energy conservation", Int. J. Sci. Eng. Res., vol. 2, pp. 1-7, 2011.
- [3] C. Wilson, T. Hargreaves and R. Hauxwell-Baldwin, "Smart homes and their users: A systematic analysis and key challenges", Pers. Ubiquitous Comput., vol. 2015, no. 19, pp. 463-476.
- [4] D.J. Cook, "How smart is your home?", Science, vol. 2012, no. 335, pp. 1579-1581
- [5] Usman Ashraf, Isbah Hameed and Muhammad Nawaz Chaudhary, "Solid Waste Management Practices Under Public and Private Sector in Lahore Pakistan", Bulletin of Environmental Studies, vol. 1, no. 4, pp. 98-105, Oct 2016
- [6] Tarapdeep Singh, Rita Mahajan and Deepak Bagai, "Smart Waste Management Using Wireless Sensor Network", International Journal of Innovative Research in Computer and Communication Engineering (IJIRCC), vol. 4, no. 6, June 2016.