



An Integrated Ultra-Capacitor Based DVR for Power Quality Improvement in the Distribution System

N. Rajesh Babu¹, S. Bhanu Sri², G.V.N. Vijaya Durga², S. Bhavana², P. P. Manideep Kumar², G.Sai Charan²

¹Assistant Professor, Department of Electrical and Electronics Engineering, PSCMR College of Engineering and Technology (Autonomous), Vijayawada, AP, India.

²Department of Electrical and Electronics Engineering, PSCMR College of Engineering and Technology (Autonomous), Vijayawada, AP, India.

To Cite this Article

N. Rajesh Babu, S. Bhanu Sri, G.V.N. Vijaya Durga, S. Bhavana, P. P. Manideep Kumar, G.Sai Charan, An Integrated Ultra-Capacitor Based DVR for Power Quality Improvement in the Distribution System, International Journal for Modern Trends in Science and Technology, 2024, 10(03), pages. 486-492. <https://doi.org/10.46501/IJMTST1003077>

Article Info

Received: 02 February 2024; Accepted: 26 March 2024; Published: 30 March 2024.

Copyright © N. Rajesh Babu et al.; This is an open access article distributed under the [Creative Commons Attribution License](#), which permits unrestricted use, distribution, and reproduction in any medium, provided the original work is properly cited.

ABSTRACT

Power quality issues in electrical distribution systems, such as voltage sags, swells, and harmonics, significantly impact the performance and reliability of electrical devices and renewable energy integration. This paper proposes an innovative solution through the development of an Ultra-Capacitor based Dynamic Voltage Restorer (DVR) designed to enhance power quality in distribution systems. The integration of ultra-capacitors provides a rapid response to power quality disturbances, offering a reliable and efficient energy storage medium that enhances the DVR's performance. The proposed system's design and control strategy are elaborated and simulated using MATLAB/Simulink, demonstrating its capability to effectively mitigate voltage sags, swells, and reduce harmonic distortion. The simulation results validate the ultra-capacitor based DVR's superiority in improving power quality, showcasing its potential as a robust solution for maintaining voltage stability and ensuring the seamless operation of sensitive loads in the distribution network

KEYWORDS: Dynamic Voltage Restorer, Ultra-Capacitor, Power Quality, Voltage Sags, Voltage Swells, Harmonic Reduction, Distribution System, MATLAB/Simulink.

1. INTRODUCTION

Power quality is a major cause of concern in the industry and it is important to maintain good power quality on the grid. Therefore, there is renewed interest in power quality products like the dynamic voltage restorer (DVR) and the active power filter (APF). The topology which resulted after the integration of dynamic voltage restorer (DVR) and active power filter (APF) through a back-back inverter topology was termed as a

unified power quality conditioner (UPQC). DVR prevents sensitive loads from experiencing voltage sags/swells and APF prevents the grid from supplying non sinusoidal currents when the load is nonlinear. The concept of integrating the DVR and APF through a back-back inverter topology was first introduced in and the topology was named as unified power quality conditioner (UPQC). The design goal of the traditional UPQC was limited is paper, energy storage integration

into the power conditioner topology is being proposed, which will allow the integrated system to provide additional functionality. With the increase in penetration of the distribution energy resources (DERs) like wind, solar, and plugin hybrid electric vehicles (PHEVs), there is a corresponding increase in the power quality problems and intermittencies on the distribution grid in the seconds to minutes time scale. Energy storage integration with DERs is a potential solution, which will increase the reliability of the DERs by reducing the intermittencies and also aid in tackling some of the power quality problems on the distribution grid.

Applications where energy storage integration will improve the functionality are being identified, and efforts are being made to make energy storage integration commercially viable on a large scale. Smoothing of DERs is one application where energy storage integration and optimal control play an important role. Super capacitor and flow battery hybrid energy storage system are integrated into the wind turbine generator to provide wind power smoothing, and the system is tested using a real-time simulator. Super capacitor is used as auxiliary energy storage for photovoltaic (PV)/fuel cell, and a model-based controller is developed for providing optimal control. a battery energy storage system-based control to mitigate wind/PV fluctuations is proposed. Multi objective optimization method to integrate battery storage for improving PV integration into the distribution grid is proposed theoretical analysis is performed to determine the upper and lower bounds of the battery size for grid-connected PV system's-based control rule is proposed to optimize the battery discharge while dispatching intermittent renewable resources. Various types of rechargeable energy storage technologies based on superconducting magnets (SMES), flywheels (FESS), batteries (BESS), and ultra capacitors (UCAPs) are compared in for integration into advanced power applications such as DVR. Efforts have been made to integrate energy storage into the DVR system, which will give the system active power capability that makes it independent of the grid during voltage disturbances.

In, cascaded H-bridge-based DVR with a thyristor-controlled inductor is proposed to minimize the energy storage requirements. In, flywheel energy storage is integrated into the DVR system to improve its steady-state series and shunt compensation of all the

rechargeable energy storage technologies, UCAPs are ideally suited for applications which need active power support in the milliseconds to second's timescale. Therefore, UCAP-based integration into the DVR system is ideal, as the normal duration of momentary voltage sags and swells is in the milliseconds to second's range. UCAPs have low-energy density and high-power density ideal characteristics for compensating voltage sags and voltage swells, which are both events that require high amount of power for short spans of time. UCAPs also have higher number of charge/discharge cycles when compared to batteries and for the same module size; UCAPs have higher terminal voltage when compared to batteries, which makes the integration easier. With the prevalence of renewable energy sources on the distribution grid and the corresponding increase in power quality problems, the need for DVRs on the distribution grid is increasing. Super-capacitor-based energy storage integration into the DVR for the distribution grid is proposed. However, the concept is introduced only through simulation and the experimental results are not presented. In this paper, UCAP-based Energy storage integration to a DVR into the distribution grid is proposed and the following application areas are addressed. Integration of the UCAP with DVR system gives active power capability to the system, which is necessary for independently compensating voltage sags and swells. Experimental validation of the UCAP, dc-dc converter, and inverter their interface and control development of inverter and dc-dc converter controls to provide sag and swell compensation to the distribution grid hardware integration and performance validation of the integrated DVR-UCAP system.

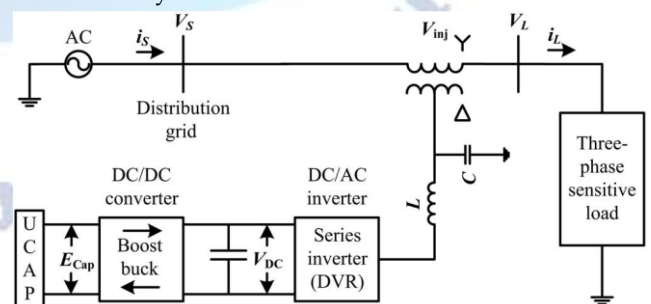

Fig.1. One-line diagram of DVR with UCAP energy storage

2. DC- AC CONVERTER (INVERTER)

An inverter is an electrical device that converts direct current (DC) to alternating current (AC); the converted AC can be at any required voltage and frequency with the use of appropriate transformers, switching, and control circuits

A. Power Quality Power quality is defined as the concept of powering and grounding sensitive equipment in a manner that is suitable to the operation of that equipment. There are many different reasons for the enormous increase in the interest in power quality. Some of the main reasons are:

- Electronic and power electronic equipment has especially become much more sensitive. Equipment has become less tolerant of voltage quality disturbances, production processes have become less tolerant of incorrect or incorrect operation of equipment, and companies have become less tolerant of production stoppages. The main perpetrators are interruptions and voltage dips, with the emphasis in discussions and in the literature being on voltage dips and short interruptions. High frequency transients do occasionally receive attention as causes of equipment malfunction.
- Equipment produces more current disturbances than it used to do. Both low and high power equipment is more and more powered by simple power electronic converters which produce a broad spectrum of distortion. There are indications that the harmonic distortion in the power system is rising, but no conclusive results are obtained due to the lack of large scale surveys.
- The deregulation of the electricity industry has led to an increased need for quality indicators. Customers are demanding, and getting, more information on the voltage quality they can expect.
- Also energy efficient equipment is an important source of power quality disturbance. Adjustable speed drives and energy saving lamps are both important sources of waveform distortion and are also sensitive to certain type of power quality disturbances. When these power quality problems become a barrier for the large scale introduction of environmentally friendly sources and users' equipment, power quality becomes an environmental issue with much wider consequences than the currently merely economic issues.

3. THREE-PHASE SERIES INVERTER

A. Power Stage

The one-line diagram of the system is shown in Fig. 1. The power stage is a three-phase voltage source inverter, which is connected in series to the grid and is responsible for compensating the voltage sags and swells; the model of the series DVR and its controller is shown in Fig. 2. The inverter system consists of an insulated gate bipolar transistor (IGBT) module, its gate-driver, LC filter, and an isolation transformer. The dc-link voltage V_{dc} is regulated at 260 V for optimum performance of the converter and the line-line voltage V_{ab} is 208 V; based on these, the modulation index m of the inverter is given by

$$m = \frac{2\sqrt{2}}{\sqrt{3}V_{dc} * n} V_{ab(rms)} \quad (1)$$

where n is the turns ratio of the isolation transformer. Substituting n as 2.5 in (1), the required modulation index is calculated as 0.52. Therefore, the output of the dc-dc converter should be regulated at 260 V for providing accurate voltage compensation. The objective of the integrated UCAP DVR system with active power capability is to compensate for temporary voltage sag (0.1–0.9 p.u.) and voltage swell (1.1–1.2 p.u.), which last from 3 s to 1 min [15].

B. Controller Implementation

There are various methods to control the series inverter to provide dynamic voltage restoration and most of them rely on injecting a voltage in quadrature with advanced phase, so that reactive power is utilized in voltage restoration [3]. Phase advanced voltage restoration techniques are complex in implementation, but the primary reason for using these techniques is to minimize the active power support and thereby the amount of energy storage requirement at the dc-link in order to minimize the cost of energy storage. However, the cost of energy storage has been declining and with the availability of active power support at the dc-link, complicated phase-advanced techniques can be avoided and voltages can be injected *in-phase* with the system voltage during a voltage sag or a swell event. The control method requires the use of a PLL to find the rotating angle. As discussed previously, the goal of this project is to use the *active power capability* of the

UCAP-DVR system and compensatetemporary voltage sags and swells.

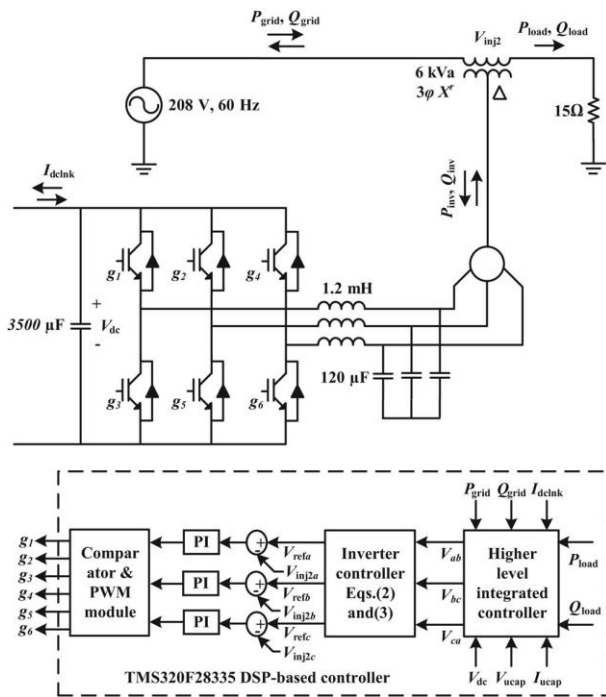

Fig. 2. Model of three-phase series inverter (DVR) and its controller with integrated higher order controller

The inverter controller implementation is based on injecting voltages *in-phase* with the supply-side line-neutral voltages. This requires PLL for estimating θ , which has been implemented using the *fictitious power method* described in [18]. Based on the estimated θ and the line-line source voltages, V_{ab} , V_{bc} , and V_{ca} (which are available for this delta-sourced system) are transformed into the $d-q$ domain and the line-neutral components of the source voltage V_{sa} , V_{sb} , and V_{sc} , which are not available, can then be estimated using

$$\begin{bmatrix} V_{sa} \\ V_{sb} \\ V_{sc} \end{bmatrix} = \begin{bmatrix} 1 & 0 \\ -\frac{1}{2} & \frac{\sqrt{3}}{2} \\ -\frac{1}{2} & -\frac{\sqrt{3}}{2} \end{bmatrix} \begin{bmatrix} \cos(\theta - \frac{\pi}{6}) & \sin(\theta - \frac{\pi}{6}) \\ -\sin(\theta - \frac{\pi}{6}) & \cos(\theta - \frac{\pi}{6}) \end{bmatrix} \begin{bmatrix} \frac{V_d}{\sqrt{3}} \\ \frac{V_q}{\sqrt{3}} \end{bmatrix} \quad (2)$$

$$\begin{bmatrix} V_{refa} \\ V_{refb} \\ V_{refc} \end{bmatrix} = m * \begin{bmatrix} (\sin \theta - \frac{V_{sa}}{169.7}) \\ (\sin(\theta - \frac{2\pi}{3}) - \frac{V_{sb}}{169.7}) \\ (\sin(\theta + \frac{2\pi}{3}) - \frac{V_{sc}}{169.7}) \end{bmatrix} \quad (3)$$

$$P_{inv} = 3V_{inj2a(rms)} I_{La(rms)} \cos \phi$$

$$Q_{inv} = 3V_{inj2a(rms)} I_{La(rms)} \sin \phi. \quad (4)$$

These voltages are normalized to unit sine waves using line-neutral system voltage of 120Vrms as reference and compared to unit sine waves *in-phase* with actual system voltages V_s from (3) to find the injected voltage

references V_{ref} necessary to maintain a constant voltage at the load terminals, where m is 0.52 from (1). Therefore, whenever there is a voltage sag or swell on the source side, a corresponding voltage V_{inj2} is injected in-phase by the DVR and UCAP system to negate the effect and retain a constant voltage V_L at the load end. The actual active and reactive power supplied by the series inverter can be computed using (4) from the rms values of the injected voltage V_{inj2a} and load current I_{La} , and ϕ is the phase difference between the two waveforms.

Bidirectional DC-DC Converter and Controller

A UCAP cannot be directly connected to the dc-link of the inverter like a battery, as the voltage profile of the UCAP varies as it discharges energy. Therefore, there is a need to integrate the UCAP system through a bidirectional dc-dc converter, which maintains a stiff dc-link voltage, as the UCAP voltage decreases while *discharging* and increases while *charging*. The

model of the bidirectional dc-dc converter and its controller are shown in Fig. 3, where the input consists of three UCAPs connected in series and the output consists of a nominal load of 213.5 Ω to prevent operation at no-load, and the output is connected to the dc-link of the inverter. The amount of active power support required by the grid during a voltage sag event is independent on the depth and duration of the voltage sag, and the dc-dc converter should be able to withstand this power during the *discharge* mode. The dc-dc converter should also be able to operate in bidirectional mode to be able to *charge* or absorb additional power from the grid during voltage swell event. In this paper, the bidirectional dc-dc converter acts as a boost converter while *discharging* power from the UCAP and acts as a buck converter while *charging* the UCAP from the grid.

A bidirectional dc-dc converter is required as an interface between the UCAP and the dc-link since the UCAP voltage varies with the amount of energy discharged while the dc-link voltage has to be stiff. Therefore, the bidirectional dc-dc converter is designed to operate in boost mode when the UCAP bank voltage is between 72 and 144 V and the output voltage is regulated at 260 V. When the UCAP bank voltage is below 72 V, the bidirectional dc-dc converter is operated in buck mode and draws energy from the grid to charge the UCAPs and the output voltage is again regulated at 260 V.

Average current mode control, which is widely explored in literature [19], is used to regulate the output voltage of the bidirectional dc–dc converter in both *buck* and *boost* modes while *charging* and *discharging* the UCAP bank. This method tends to be more stable when compared to other methods such as voltage mode control and peak current mode control. Average current mode controller is shown in Fig. 3, where the dc-link and actual output voltage V_{out} is compared with the reference voltage V_{ref} and the error is passed through the voltage compensator $C_1(s)$, which generates the average reference current I_{ucref} . When the inverter is *discharging* power into the grid during voltage sag event, the dc-link voltage V_{out} tends to go below the reference V_{ref} and the error is positive; I_{ucref} is positive and the dc–dc converter operates in *boost* mode. When the inverter is absorbing power from the grid during voltage swell event or *charging* the UCAP, V_{out} tends to increase above the reference V_{ref} and the error is negative; I_{ucref} is negative and the dc–dc converter operates in *buck* mode. Therefore, the sign of the error between V_{out} and V_{ref} determines the sign of I_{ucref} and thereby the direction of operation of the bidirectional dc–dc converter. The reference current I_{ucref} is then compared to the actual UCAP current (which is also the inductor current) I_{uc} and the error is then passed through the current compensator $C_2(s)$. The compensator transfer functions, which provide a stable response, are given by

$$C_1(s) = 1.67 + \frac{23.81}{s}$$

$$C_2(s) = 3.15 + \frac{1000}{s}$$

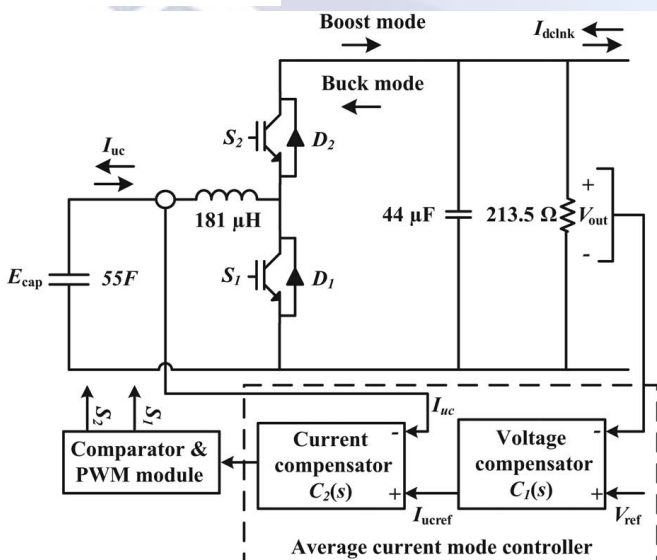

Fig. 3. Model of the bidirectional dc–dc converter and its controller.

4. SIMULATION RESULTS:

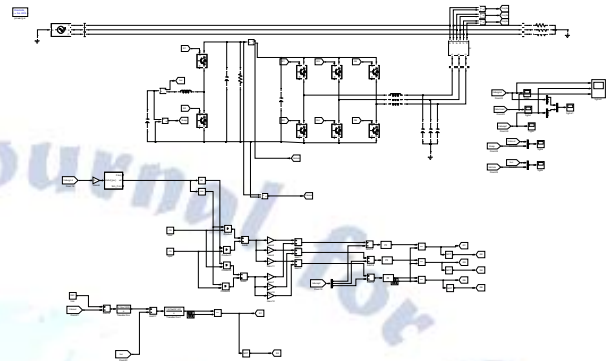

Fig 4: Simulation Circuit

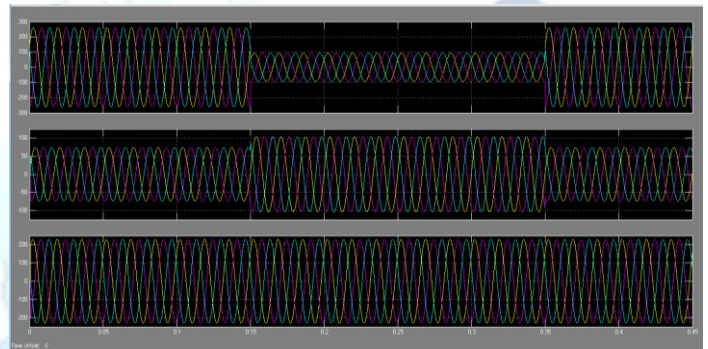
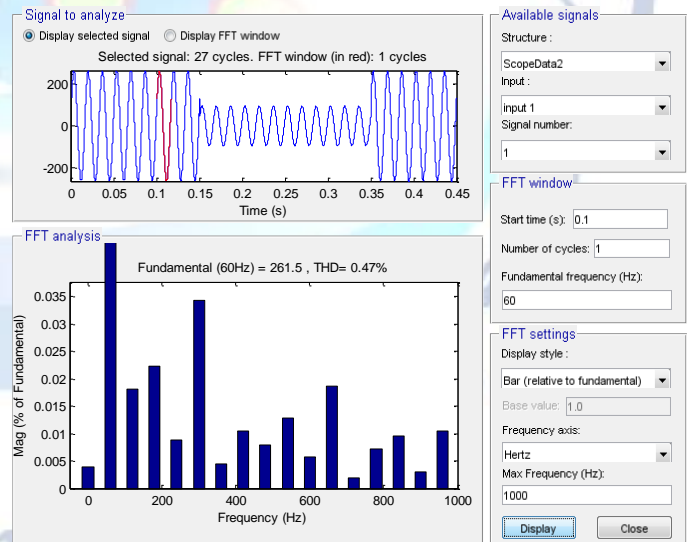
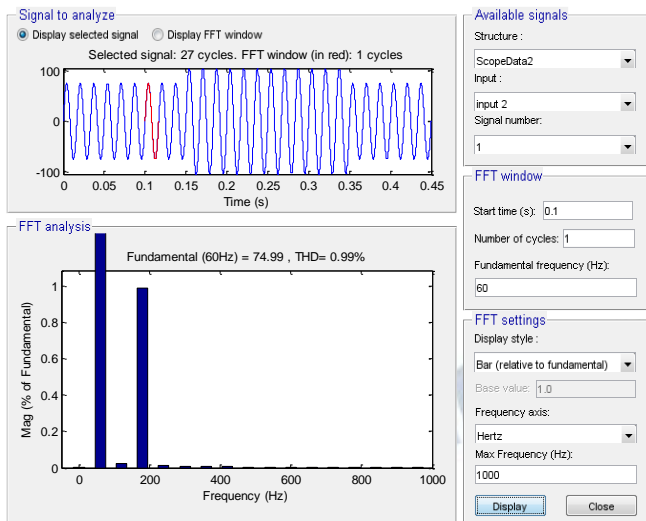

Fig.5. Insert Ultracapacitor Voltage for load maintained



Input THD



DVR THD

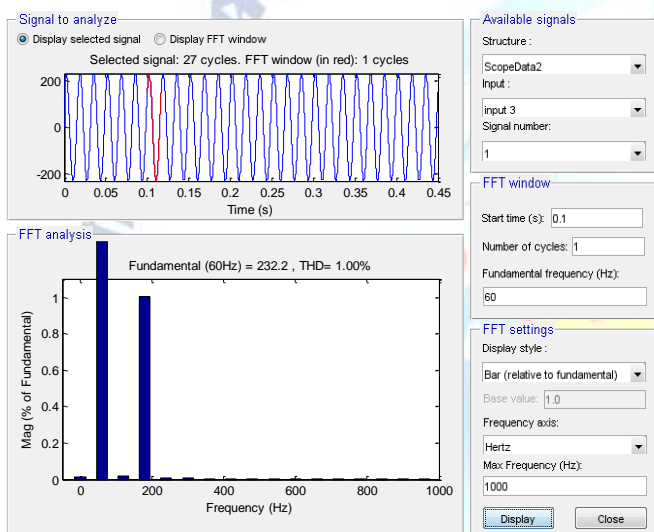

Load THD

5. CONCLUSION

In this paper, the concept of integrating UCAP-based rechargeable energy storage to a power conditioner system to improve the power quality of the distribution grid is presented. With this integration, the DVR portion of the power conditioner will be able to independently compensate voltage sags and swells and the APF portion of the power conditioner will be able to provide active/reactive power support and renewable intermittency smoothing to the distribution grid. UCAP integration through a bidirectional dc–dc converter at the dc-link of the power conditioner is proposed. The control strategy of the series inverter (DVR) is based on in phase compensation and the control strategy of the shunt inverter (APF) is based on i_d – i_q method. Designs of major components in the power stage of the bidirectional dc–dc converter are discussed. Average current mode control is used to regulate the output

voltage of the dc–dc converter due to its inherently stable characteristic. A higher level integrated controller that takes decisions based on the system parameters provides inputs to the inverters and dc–dc converter controllers to carry out their control actions. The simulation of the integrated UCAP-PC system which consists of the UCAP, bidirectional dc–dc converter, and the series and shunt inverters is carried out using MATLAB. The simulation of the UCAP-PC system is carried out using PSCAD. Hardware experimental setup of the integrated system is presented and the ability to provide temporary voltage sag compensation and active/reactive power support and renewable intermittency smoothing to the distribution grid is tested. Results from simulation and experiment agree well with each other thereby verifying the concepts introduced in this paper. Similar UCAP based energy storages can be deployed in the future in a microgrid or a low-voltage distribution grid to respond to dynamic changes in the voltage profiles and power profiles on the distribution grid.

Conflict of interest statement

Authors declare that they do not have any conflict of interest.

REFERENCES

- [1] Deepak Somayajula, Member, IEEE, and Mariesa L. Crow, Fellow, IEEE, "An Integrated Dynamic Voltage Restorer-Ultracapacitor Design for Improving Power Quality of the Distribution Grid", IEEE Transactions on Sustainable Energy, Vol. 6, No. 2, April 2015.
- [2] N. H. Woodley, L. Morgan, and A. Sundaram, "Experience with an inverter-based dynamic voltage restorer," IEEE Trans. Power Del., vol. 14, no. 3, pp. 1181–1186, Jul. 1999.
- [3] S. S. Choi, B. H. Li, and D.M. Vilathgamuwa, "Dynamic voltage restoration with minimum energy injection," IEEE Trans. Power Syst., vol. 15, no. 1, pp. 51–57, Feb. 2000.
- [4] D. M. Vilathgamuwa, A. A. D. R. Perera, and S. S. Choi, "Voltage sag compensation with energy optimized dynamic voltage restorer," IEEE Trans. Power Del., vol. 18, no. 3, pp. 928–936, Jul. 2003.
- [5] Y. W. Li, D. M. Vilathgamuwa, F. Blaabjerg, and P. C. Loh "A robust control scheme for medium-voltage-level DVR implementation," IEEE Trans. Ind. Electron., vol. 54, no. 4, pp. 2249–2261, Aug. 2007.
- [6] A. Ghosh and G. Ledwich, "Compensation of distribution system voltage using DVR," IEEE Trans. Power Del., vol. 17, no. 4, pp. 1030–1036, Oct. 2002.

- [7] A. Elnady and M. M. A. Salama, "Mitigation of voltage disturbances using adaptive Perceptron-based control algorithm," IEEE Trans. Power Del., vol. 20, no. 1, pp. 309–318, Jan. 2005.
- [8] P. R. Sanchez, E. Acha, J. E. O. Calderon, V. Feliu, and A. G. Cerrada, "A versatile control scheme for a dynamic voltage restorer for power quality improvement," IEEE Trans. Power Del., vol. 24, no. 1, pp. 277–284, Jan. 2009

