



Enhancement of Power Quality by UPQC Based on Voltage Source Converter



K. Rohini Kumar¹ | N. Vijaya Kumar²

¹PG Scholar, Department of EEE, Godavari Institute of Engineering and Technology, Rajahmundry, Andhra Pradesh, India.

²Assistant Professor, Department of EEE, Godavari Institute of Engineering and Technology, Rajahmundry, Andhra Pradesh, India.

ABSTRACT

In modern power system consists of wide range of electrical, electronic and power electronic equipment in commercial and industrial applications. Since most of the electronic equipment's are nonlinear in nature these will induce harmonics in the system, which affect the sensitive loads to be fed from the system. These problems are partially solved with the help of LC passive filters. However, this kind of filter cannot solve random variation in the load current wave form and voltage wave form. Active filters can resolve this problem. However, the cost of active filters is high. They are difficult to implement in large scale. Additionally, they also present lower efficiency than shunt passive filters. One of the many solutions is the use of a combined system of shunt and active series filters like Unified Power Quality Conditioner (UPQC) which aims at achieving a low cost under highly effective control. The UPQC device combines a shunt active filter together with a series active filter in a back-to-back configuration, to simultaneously compensate the supply voltage and the load current or to mitigate any type of voltage and current fluctuations and power factor correction in a power distribution network, such that improved power quality can be made available at the point of common coupling. The control strategies are modeled using MATLAB/SIMULINK. The performance is also observed under influence of utility side disturbances such as harmonics and voltage sags. The simulation results are compared without and with UPQC for the verification of results.

KEYWORDS:

Power Quality, harmonics, voltage sag, active power filter, unified power quality conditioner (upqc).

*Copyright © 2016 International Journal for Modern Trends in Science and Technology
All rights reserved.*

I. INTRODUCTION

With the advent of power semiconductor switching devices, like thyristors, GTO's (Gate Turn off thyristors), IGBT's (Insulated Gate Bipolar Transistors) and many more devices, control of electric power has become a reality. Such power electronic controllers are widely used to feed electric power to electrical loads, such as adjustable speed drives (ASD's), furnaces, computer power supplies, HVDC systems etc.

The power electronic devices due to their inherent non-linearity draw harmonic and reactive power from the supply. In three phase

systems, they could also cause unbalance and draw excessive neutral currents. The injected harmonics, reactive power burden, unbalance, and excessive neutral currents cause low system efficiency and poor power factor.

In addition to this, the power system is subjected to various transients like voltage sags, swells, flickers etc. These transients would affect the voltage at distribution levels. Excessive reactive power of loads would increase the generating capacity of generating stations and increase the transmission losses in lines. Hence supply of reactive power at the load ends becomes essential.

Power Quality (PQ) has become an important issue since many loads at various distribution ends like adjustable speed drives, process industries, printers; domestic utilities, computers, microprocessor based equipments etc. have become intolerant to voltage fluctuations, harmonic content and interruptions.

Power Quality (PQ) mainly deals with issues like maintaining a fixed voltage at the Point of Common Coupling (PCC) for various distribution voltage levels irrespective of voltage fluctuations, maintaining near unity power factor power drawn from the supply, blocking of voltage and current unbalance from passing upwards from various distribution levels, reduction of voltage and current harmonics in the system and suppression of excessive supply neutral current.

Conventionally, passive LC filters and fixed compensating devices with some degree of variation like thyristor switched capacitors, thyristor switched reactors were employed to improve the power factor of ac loads. Such devices have the demerits of fixed compensation, large size, ageing and resonance. Nowadays equipments using power semiconductor devices, generally known as active power filters (APF's), Active Power Line Conditioners (APLC's) etc. are used for the power quality issues due to their dynamic and adjustable solutions. Flexible AC Transmission Systems (FACTS) and Custom Power products like STATCOM (Static synchronous Compensator), DVR (Dynamic Voltage Restorer), etc. deal with the issues related to power quality using similar control strategies and concepts. Basically, they are different only in the location in a power system where they are deployed and the objectives for which they are deployed [1].

Active Power Filters can be classified, based on converter type, topology and the number of phases. Converter types are Current Source Inverter (CSI) with inductive energy storage or Voltage Source Inverter (VSI) with capacitive energy storage. The topology can be shunt, series or combination of both. The third classification is based on the number of phases, such as single phase systems, three phase systems or three phase four wire systems.

In this thesis, various extractions algorithms for generating reference signals and various modulation techniques for generating pulses already developed and published are discussed. Criterion for selection of dc link capacitor and interfacing filter design are also discussed.

The Objective of this paper, one such APLC known as Unified Power Quality Conditioner (UPQC), which can be used at the PCC for improving power quality, is designed, simulated using proposed control strategy and the performance is evaluated for various nonlinear loads [2] [3].

II. POWER QUALITY PROBLEMS

Power quality is very important term that embraces all aspects associated with amplitude, phase and frequency of the voltage and current waveform existing in a power circuit. Any problem manifested in voltage, current or frequency deviation that results in failure of the customer equipment is known as power quality problem.

The increasing number of power electronics based equipment has produced a significant impact on the quality of electric power supply. The lack of quality power can cause loss of production, damage of equipment or appliances, increased power losses, interference with communication lines and so forth. Therefore, it is obvious to maintain high standards of power quality [3].

The major types of power quality problems are: Interruption, Voltage-sag, Voltage-swell, Distortion, and harmonics.

A. Voltage Sags

Voltage sag or dip represent a voltage fall to 0.1 to 0.9 p.u. and existing for less than one minute. This is shown in fig 1.

Voltage sag can cause loss of production in automated process since a voltage sag trip a motor or cause its controller to malfunction namely microprocessor based control system, programmable logic controller, adjustable speed drives, that may lead to a process stoppage, tripping of contractors and loss of efficiency of electric machine. Impact of long duration variation is greater than those of short duration variation [4].

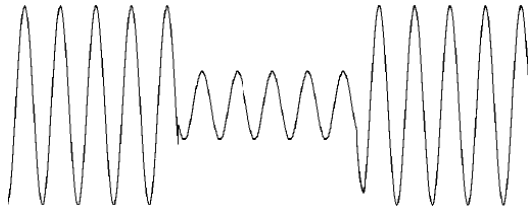

Fig. 1 Voltage Sag

B. Voltage Swell

Voltage swell is the rise in voltage of greater than 1.1 p.u. and exists for less than one minute shown in fig 2.

Swells are usually associated with system fault conditions, but they are much less common than voltage sags. A swell can occur due to a single line-to-ground fault on the system which can result temporary voltage rise on the other unwanted phases. Swells can also be caused by switching off a large load or switching on a large capacitor bank. Voltage swells can put stress on computer and many home appliances. It also causes tripping of protective circuit of an adjustable speed drive [5].

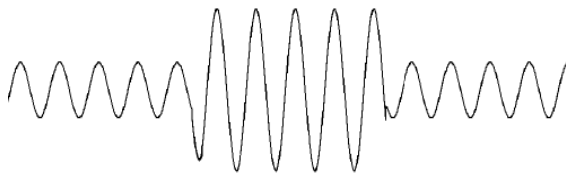

Fig. 2 Voltage Swell

C. High Harmonic in Distribution System

It is a sinusoidal component of a periodic wave having a frequency that is an integral multiple of the fundamental frequency as shown in fig.3. Harmonics can be considered as voltages or current present on an electrical system at some multiple of the fundamental frequency.

Non-linear elements in power system such as power electronic devices, static power converters, arc discharge devices, and lesser degree rotating machines create current distortion. Static Power converters of electrical power are largest nonlinear loads and are used in industry for a verity of purposes, such as electrochemical power supplies adjustable speed drives, and uninterruptible power supplies. These devices are useful because convert ac to dc, dc to dc, dc to ac, and ac to

ac. Harmonics cause wave from distortion power system problems such as communication interference, heating, and solid-state device malfunction can be direct result of harmonics [4].

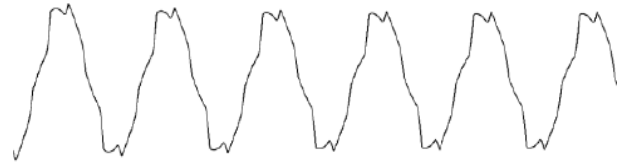

Fig. 3 Voltage harmonics

III. BASIC CONFIGURATION OF UPQC

In recent years, solutions based on flexible ac transmission systems (FACTS) have appeared. The application of FACTS concepts in distribution systems has resulted in a new generation of compensating devices. A unified power-quality conditioner (UPQC) is the extension of the unified power-flow controller (UPFC) concept at the distribution level. It consists of combined series and shunt converters for simultaneous compensation of voltage and current imperfections in a supply feeder. However, a UPFC only needs to provide balance shunt and/or series compensation, since a power transmission system generally operates under a balanced and distortion free environment. On the other hand, a power distribution system may contain dcomponents, distortion, and unbalance both in voltages and currents. Therefore, a UPQC should operate under this environment while performing shunt and/or series compensation [6].

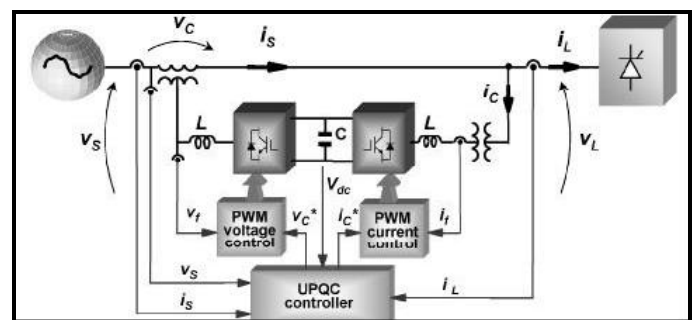

Fig: 4 Basic Configuration of the UPQC

The main purpose of a UPQC is to compensate for supply voltage power quality issues, such as, sags, swells, unbalance, flicker, harmonics, and for load current power quality problems, such as, harmonics, unbalance, reactive current, and neutral current. Fig.1 shows a single-line representation of the UPQC system configuration. The key components of this system are as follows.

1. Two inverters one connected across the load which acts as a shunt APF and other connected in series with the line as that of series APF.
2. Shunt coupling inductor L_{Sh} is used to interface the shunt inverter to the network. It also helps in smoothing the current wave shape. Sometimes an isolation transformer is utilized to electrically isolate the inverter from the network.
3. A common dc link that can be formed by using a capacitor or an inductor. In Fig. 1, the dc link is realized using a capacitor which interconnects the two inverters and also maintains a constant self-supporting dc bus voltage across it.
4. An LC filter that serves as a passive low-pass filter (LPF) and helps to eliminate high-frequency switching ripples on generated inverter output voltage.
5. Series injection transformer that is used to connect the series inverter in the network. A suitable turn ratio is often considered to reduce the current or and voltage rating of the series inverter.

The integrated controller of the series and shunt APF of the UPQC to provide the compensating voltage reference V_C^* and compensating current reference I_C^* to be synthesized by PWM converters [7], [8].

The shunt active power filter of the UPQC can compensate all undesirable current components, including harmonics, imbalances due to negative and zero sequence components at the fundamental frequency. In order to cancel the harmonics generated by a nonlinear load, the shunt inverter should inject a current as governed by the following equation:

$$I_C(\omega t) = I^*_L(\omega t) - I_S(\omega t) \quad (1)$$

Where $I_C(\omega t)$, $I^*_L(\omega t)$ and $I_S(\omega t)$ represent the shunt inverter current, reference load current, and actual source current, respectively.

The series active power filter of the UPQC can compensate the supply voltage related problems by injecting voltage in series with line to achieve distortion free voltage at the load terminal. The series inverter of the UPQC can be represented by following equation:

$$V_C(\omega t) = V^*_L(\omega t) - V_S(\omega t) \quad (2)$$

Where $V_C(\omega t)$, $V^*_L(\omega t)$ and $V_S(\omega t)$ represent the series inverter voltage, reference load voltage, and actual source voltage, respectively [9] [10].

IV. CONTROL STRATEGIES OF UPQC

A. System Configuration

Basic block diagram of UPQC is shown in Fig 5, where as the overall control circuit is shown in the Fig 7. The voltage at PCC may be or may not be distorted depending on the other non-linear loads connected at PCC. Here we assume the voltage at PCC is distorted. Two voltage source inverters are connected back to back, sharing a common dc link. One inverter is connected parallel with the load. It acts as shunt APF, helps in compensating load harmonic current as well as to maintain dc link voltage at constant level. The second inverter is connected in series with utility voltage by using series transformers and helps in maintaining the load voltage sinusoidal.

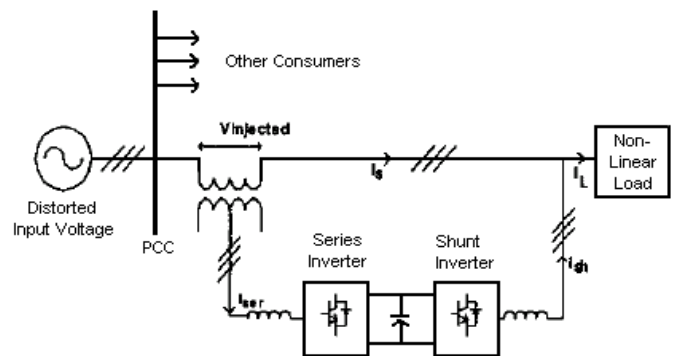

Fig 5 Basic Block Diagram of UPQC

B. Reference Generation (Phase Locked Loop)

Reference currents and voltages are generated using Phase Locked Loop (PLL). The control strategy is based on the extraction of Unit Vector Templates from the distorted input supply. These templates will be then equivalent to pure sinusoidal signal with unity (p.u.) amplitude. The extraction of unit vector templates is shown in the Fig 6.

The 3-ph distorted input source voltage at PCC contains fundamental component and distorted component. To get unit input voltage vectors U_{abc} , the input voltage is sensed and

multiplied by gain equal to $1/V_m$, where V_m is equal to peak amplitude of fundamental input voltage. These unit input voltage vectors are taken to phase locked loop (PLL). With proper phase delay, the unit vector templates are generated.

$$\begin{aligned} U_a &= \sin(\omega t) \\ U_b &= \sin(\omega t - 120) \\ U_c &= \sin(\omega t + 120) \end{aligned} \quad (3)$$

Multiplying the peak amplitude of fundamental input voltage with unit vector templates of equation (3) gives the reference load voltage signals,

$$V_{abc}^* = V_m \cdot U_{abc} \quad (4)$$

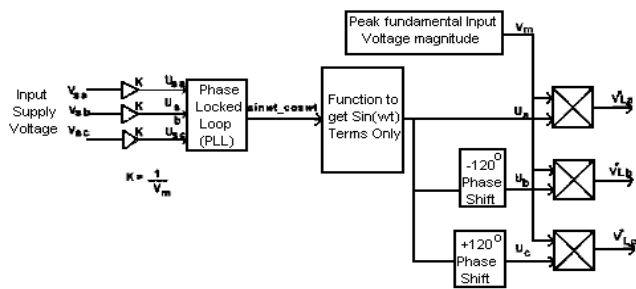

Fig 6 Extraction of Unit Vector Templates and 3-Ph Reference Voltages

In order to have distortion less load voltage, the load voltage must be equal to these reference signals. The measured load voltages are compared with reference load voltage signals. The error generated is then taken to a hysteresis controller to generate the required gate signals for series APF.

The unit vector template can be applied for shunt APF to compensate the harmonic current generated by non-linear load. The shunt APF is used to compensate for current harmonics as well as to maintain the dc link voltage at constant level. To achieve the abovementioned task the dc link voltage is sensed and compared with the reference dc link voltage. A PI controller then processes the error. The output signal from PI controller is multiplied with unit vector templates of equation (3) giving reference source current signals. The source current must be equal to this reference signal. In order to follow this reference current signal, the 3-ph source currents are sensed and compared with reference current signals. The error generated is then processed by a hysteresis current controller with suitable band, generating gating signals for shunt APF.

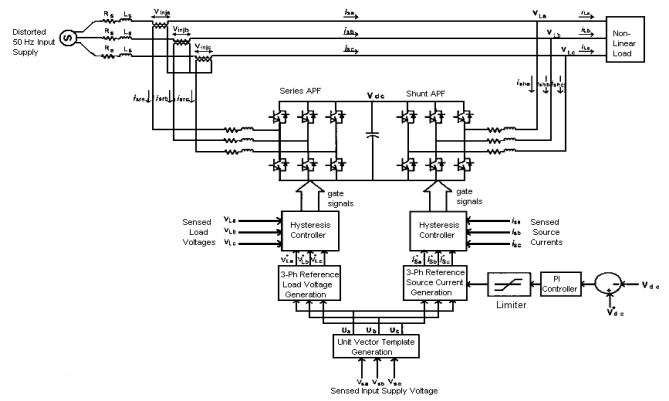

Fig 7 Overall Control Circuit Configuration of UPQC

C. Modulation Method (Hysteresis Control)

The UPQC uses two back-to-back connected three phase VSI's sharing a common dc bus. The hysteresis controller is used here to control the switching of the both VSI's.

Hysteresis control law for Series APF:

If $(V_{act}) > (V_{ref} + HB)$ upper switch of a leg is ON and lower switch is OFF.

If $(V_{act}) < (V_{ref} - HB)$ upper switch of a leg is OFF and lower switch is ON.

Hysteresis control law for Shunt APF:

If $(i_{act}) > (i_{ref} + HB)$ upper switch of a leg is ON and lower switch is OFF.

If $(i_{act}) < (i_{ref} - HB)$ upper switch of a leg is OFF and lower switch is ON.

where HB is the hysteresis band.

V. SIMULATION RESULTS

To verify the operating performance of the proposed UPQC, a 3-phase electrical system, a PLL extraction circuit with hysteresis controlled UPQC is simulated using MATLAB software. The simulation diagram is shown in figure 8.

The simulation results are shown in the Fig 9. Both the series and shunt APF's are put into the operation from 0.15 seconds time instant, such that both series and shunt APF's are operated as UPQC.

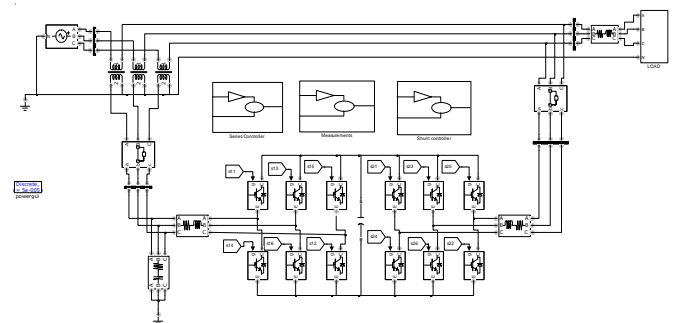

Fig 8 Matlab/Simulink Model

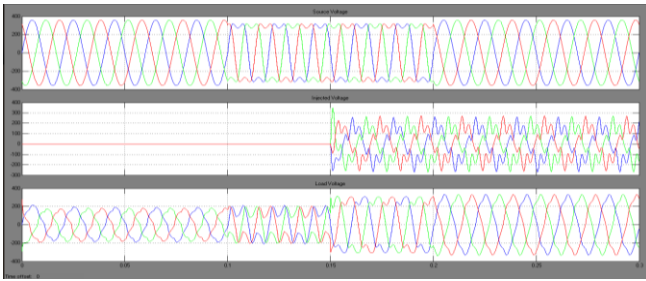

Fig 9 Simulation Results (a) Supply Voltage (b) Injected Voltage through Series Converter and (c) Load Voltage

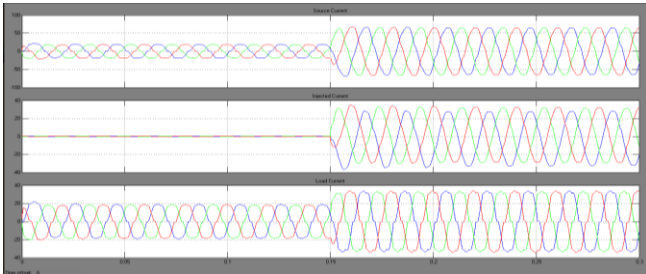

Fig 10 Simulation Results (a) Supply Current (b) Current at series converter and (c) Load Current

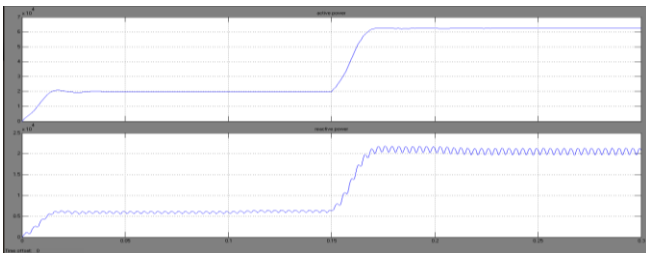

Fig 11 Simulation Results (a) Active Power and (b) Reactive Power

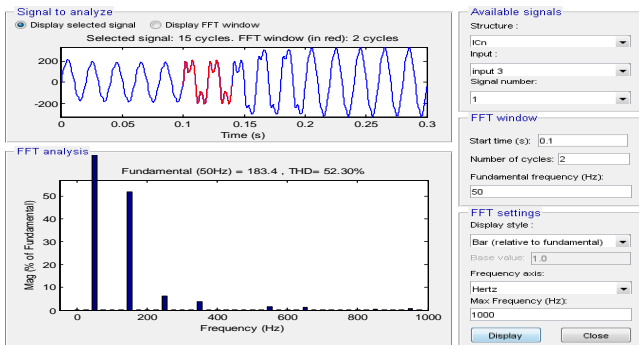

Fig 12 THD Analysis without UPQC (52.30%)

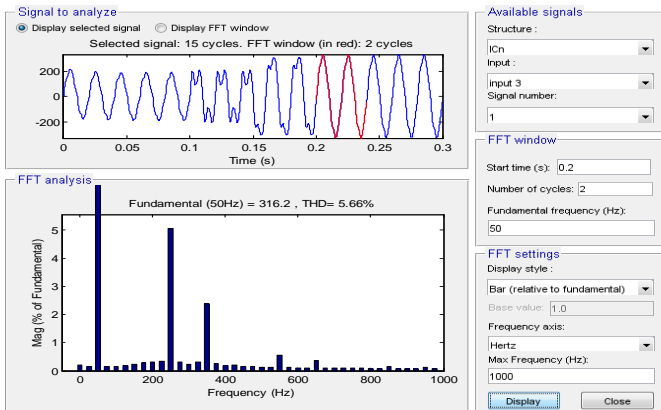

Fig 13 THD Analysis with UPQC (5.66%)

Table 1 Voltage and current harmonics (THD's) of UPQC

Order of harmonics	Without UPQC utility side voltage	With UPQC utility side voltage
3 rd &5 th	52.33%	5.66%

VI. CONCLUSION

Custom power devices like DVR, D-STATCOM, and UPQC can enhance power quality in the distribution system. Based on the power quality problem at the load or at the distribution system, there is a choice to choose particular custom power device with specific compensation. Unified Power Quality Conditioner (UPQC) is the combination of series and shunt APF, which compensates supply voltage and load current imperfections in the distribution system.

The UPQC considered in this project is a multifunction power conditioner which can be used to compensate for various voltage disturbance of the power supply, to correct any voltage fluctuation and to prevent the harmonic load current from entering the power system.

A simple control technique based on unit vector templates generation is proposed for UPQC. Proposed model has been simulated in MATLAB. The simulation results show that the input voltage harmonics and current harmonics caused by non-linear load can be compensated effectively by the proposed control strategy. The closed loop control schemes of direct current control, for the proposed UPQC have been described. A suitable mathematical model of the UPQC has been developed with PI controller. Simulation results show that with UPQC THD is minimum for both the voltage and current.

REFERENCES

- [1] H.Akagi, "Trends in active power line conditioners,"IEEE Trans. Power Electron., vol. 9, no. 3, pp.263–268, May 1994.
- [2] B. Singh, K. Al-Haddad, and A. Chandra, "A review of active filters for power quality improvement," IEEE Trans. Ind. Electron., vol. 46, no. 5, pp. 960–971, Oct. 1999.
- [3] M. El-Habrouk, M. K. Darwish, and P. Mehta, "Active power filters: A review," IEE Electr. Power Appl., vol. 147, no. 5, Sep.2000, pp.403–413.

- [4] S. Moran, "A line voltage regulator/conditioner for harmonic-sensitive load isolation," in Proc. Ind. Appl. Soc. Annu Meet. Conf., Oct. 1-5, 1989, pp. 947-951.
- [5] M.P. Pålsson, K. Uhlen, J.O.G. Tande. "Large-scale Wind Power Integration and Voltage Stability Limits in Regional Networks"; IEEE2002.p.p. 762-769.
- [6] S. Muthu and J. M. S. Kim, "Steady-state operating Characteristics of unified active power filters," in Proc. Appl. Power Electron. Conf., Feb. 23-27, 1997, pp. 199-205.
- [7] H. Fujita and H. Akagi, "The unified power quality conditioner: The Integration of series and shunt active filters," IEEE Trans. Power Electron. vol. 13, no. 2, pp. 315-322, Mar. 1998.
- [8] M. Aredes, K. Heumann, and E. H. Watanabe, "An universal active Power line conditioner," IEEE Trans. Power Del., vol. 13, no. 2, pp. 545-551, Apr. 1998.
- [9] M. Hu and H. Chen, "Modeling and controlling of unified power Quality conditioner," in Proc. Adv. Power Syst. Control Operation Manage., Oct 30-Nov. 1, 2000, pp. 431-435.
- [10] G. Jianjun, X. Dianguo, L. Hankui, and G. Maozhong, "Unified power quality conditioner (UPQC): The principle, control and application," in Proc. Power Convers. Conf., 2002, pp. 80-85.