



Mitigation of Voltage Sag for Power Quality Improvement Using DPFC System

Dr.L.V.Narasimha Rao

Professor ,Department of EEE, Priyadarshini Institute of Technology & Science,
Chintalapudi, Guntur (Dt),Andhra Pradesh

Article History

Received on: 15-01-2016
Accepted on: 20-01-2016
Published on: 26-01-2016

Keyword

DPFC ,
UPFC
FACTS,
matlab/simulink

ABSTRACT

A new control scheme to improve and maintain the power quality of an electrical power system by design of distributed power flow controller. Generally, In case of modern power utilities have problems like challenges in growth of electricity in case of non-linear loads in grid connected systems. In this paper, we introduced a new FACTS method i.e. distributed power flow controller which is similar to other series-shunt controller types. This DPFC method is also used like UPFC to mitigate voltage sag and swell as a power quality issue. In DPFC, we eliminate the common dc link capacitor and instead of single three phase series converter it has three individual single phase converters. In this paper the control circuit is designed by using series referral voltages, branch currents. The evaluated values are obtained by using MATLAB/SIMULINK.

*Copyright © 2015 International Journal for Modern Trends in Science and Technology
All rights reserved.*

I. INTRODUCTION

Because of power demand grows dramatically, and extension in transmission and generation is restricted with the rigid environmental constraints and the limited availability of resource. But in case of transfer of power from the generation units to the utility customers, the term power quality is a measure of how the elements affect the system as a whole[1]-[2]. From consumer point of view, the power quality issue is concentrated about current, voltage or frequency deviation which causes the failure of power[3]-[4]. For solving such type of power quality problem a new method based on the power electronic based equipment's such as flexible alternating current transmission system (FACTS) and custom power devices (DVR) which are used in both transmission and distribution control, respectively, should be developed. But, the majority of problems transmission lines are such as sag (voltage dip), swell (over voltage) and interruption[5]-[6]. To mitigate this type of power quality problems, the utilization of FACTS devices such as unified power flow controller (UPFC) and static synchronous compensator (STATCOM) can be helpful. In this paper we introduce a new method like distributed power flow controller (DPFC) which has similar configuration to UPFC structure[7]-[8]. The DPFC has a combination of parallel converter and multiple series converters which is used to balance the transmission line parameters, such as bus voltage, line impedance, and transmission angle[9]-[10].

II. WORKING OF DPFC

The DPFC consists of parallel and series connected converters. The parallel converter is similar as a STATCOM, while the series converters employ the D-FACTS concept such as DVR. Each converter within the DPFC is independent and has a separate DC link capacitor to provide the required DC voltage. Illustration. 1 shows the structure of single machine system with DPFC. The control capability of the Unified power flow controller is given by the back-to-back connection between the shunt and the series converters with DC link, which allows the active power to exchange freely. To ensure that the DPFC has the same control capability as the UPFC device, a method that allows the exchange of active power between converters without DC link is the prerequisite. Therefore, it is allows to exchange

the active power through the AC terminals of the converters.

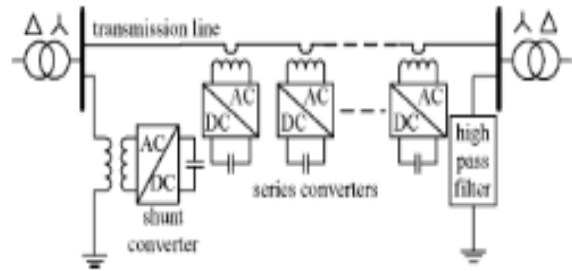

Fig 1: Basic Configuration of DPFC

A. Advantages of DPFC:

The Distributed Power Flow Controller has the following advantages in comparison with UPFC, such as:

- More capability to control. The DPFC can control all parameters of transmission line such as, impedance, load angle and voltage magnitude.
- High efficiency. The series converters redundancy increases the DPFC reliability during converters operation.
- It means, if one of series converters fails, the others can continue to work. Least Economy.

III. CONTROLL CIRCUIT OF DPFC

According to illustration 2 the DPFC has three types of control strategies: i.e. Main controller, DVR controller and Static controller.

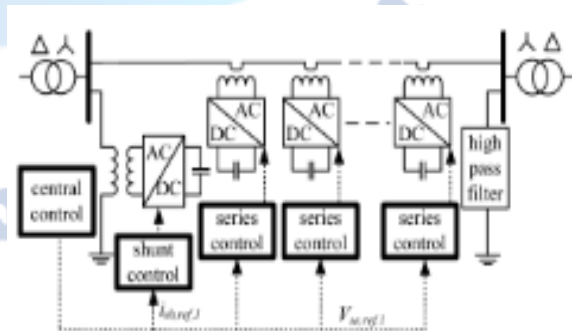

Fig 2: Control Diagram of DPFC

These three controllers are explained as follows:

A. Central Controller:

The central controller is used to control dvr and static controllers by generation of referral signals (like series voltages and currents).

B. Series Controller:

The main purpose of this series controller is to maintain the voltage of capacitor of its own converters and to generate series voltages at the natural frequency. This controller requires inputs as series capacitor voltages, line voltages and reference capacitor voltages in direct and quadrature axis frame. Generally, these series controllers has first order low pass and third order band pass filters to create natural and 3rd order harmonic currents. The control structure for series controller is shown in figure 3.

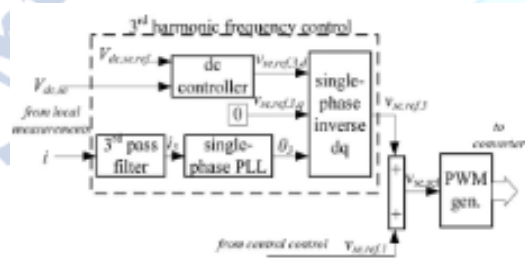

Fig 3: Block Diagram for Series Controller

IV. SHUNT CONTROLLER

The control diagram of the shunt converter is shown in figure 4. Main aim of the shunt control is to insert a 3rd harmonic current into the transmission line to provide active power for the dvr converters. The static converter have three phase converter which is back to back connected with single phase converter. In this the three phase converter absorbs active power from grid and controls Dc voltage of capacitor between this converters

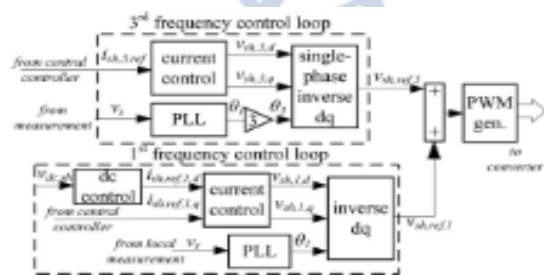

Fig 4: Control Diagram for Shunt Controller

V. SIMULATION RESULTS

The case study, for voltage dip condition is implemented in a single machine system and analyzed observations are shown below. The experimental diagram is implemented by basic diagram which is shown in figure 5.

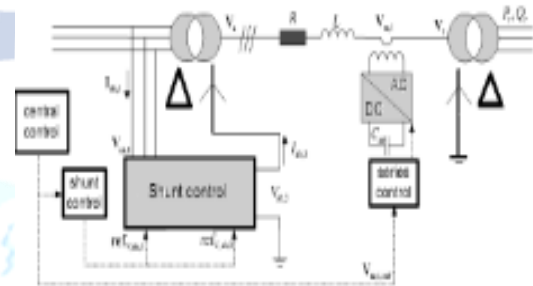

Fig 5: Structure of DPFC

In this system the time duration for this fault is 500ms to 1500ms. The three phase fault causes observable voltage sag during this time as shown in figure 6. The voltage sag values is about 0.65 per unit and the mitigation of voltage sag by DPFC is shown in figure 7

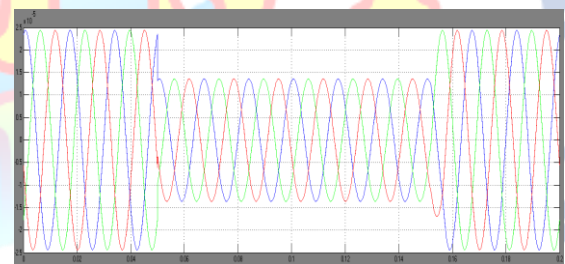

Fig 6: Simulation results for voltage sag condition

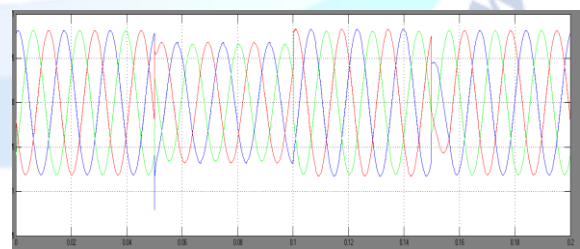

Fig 7: Simulation results for mitigation of Voltage sag with DPFC system

After creating the fault the load current swell around 0.2 per unit. The simulation results of load current in case of swell condition and mitigation of current are shown in figure 8 and figure 9.

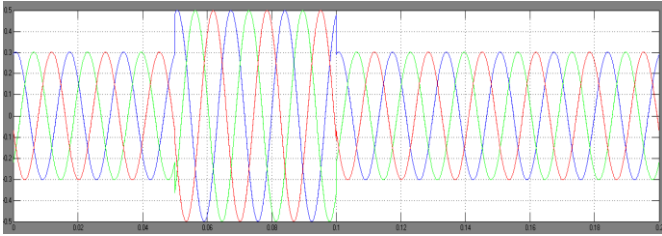

Fig 8: Simulation results for current swell condition

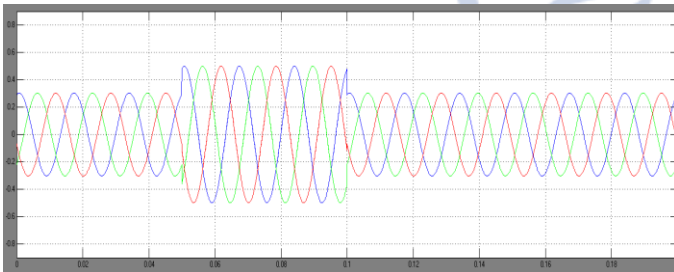

Fig 9: Simulation results for mitigation of current swell with DPFC system

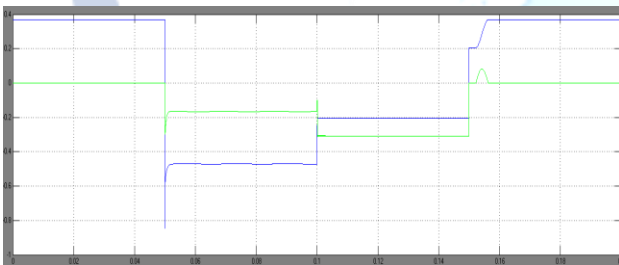

Fig 10: simulation results for active and reactive powers

VI. CONCLUSION

In this paper we implemented a new concept for controlling power quality problems by Distributed Power Flow Controller device. The proposed concept of the DPFC approach is mathematically formulated and analyzed for voltage dips and their mitigations for a three phase source with linear load. The experimental results of DPFC show the effectiveness of DPFC in power quality enhancement as compared to all other FACTS devices.

REFERENCES

- [1] Y. Yorozu, M. Hirano, K. Oka, and Y. Tagawa, "Electron spectroscopy studies on magneto-optical media and plastic substrate interface," *IEEE Transl. J. Magn. Japan*, vol. 2, pp. 740-741, August 1987 [Digests 9th Annual Conf. Magnetics Japan, p. 301, 1982].
- [2] J. Faiz, G. H. Shahgholian, and M. Torabian, "Design and simulation of UPFC for enhancement of power quality in transmission lines," *IEEE International Conference on Power System Technology*, vol. 24, no. 4, 2010.

- [3] A. E. Emanuel and J. A. McNeill, "Electric power quality," *Annu. Rev. Energy Environ*, 1997.
- [4] I. N. R. Patne and K. L. Thakre "Factor affecting characteristics of voltage sag due to fault in the power system," *Serbian Journal of Electrical engineering*. vol. 5, no.1, 2008.
- [5] B. Singh, K. Al-Haddad, and A. Chandra, "A review of active filters for power quality improvement," *IEEE Trans. Ind. Electron.* vol. 46, no. 5, pp. 960-971, 1999.
- [6] M. A. Hannan and A. Mohamed, member IEEE, "PSCAD/EMTDC simulation of unified series-shunt compensator for power quality improvement," *IEEE Transactions on Power Delivery*, vol. 20, no. 2, 2005.
- [7] A. L. Olimpo and E. Acha, "Modeling and analysis of custom power systems by PSCAD/EMTDC," *IEEE Trans. Power Delivery*, vol. 17, no.1, pp. 266-272, 2002.
- [8] P. Pohjanheimo and E. Lakervi, "Steady state modeling of custom power components in power distribution networks," in *Proc. IEEE Power Engineering Society Winter Meeting*, vol. 4, Jan, pp. 2949-2954, 2000.
- [9] Z. H. Yuan, S. W. H de Haan, B. Frreira, and D. Cevoric, "A FACTS device: Distributed power flow controller (DPFC)," *IEEE Transaction on Power Electronics*, vol.25, no.10, October, 2010.
- [10] Z. H. Yuan, S. W. H de Haan, and B. Frreira "DPFC control during shunt converter failure," *IEEE Transaction on Power Electronics* 2009.