



Bridgeless and Independent Zeta Luo Converter Based Electric Vehicle Charger

Anapana Jeevean Reddy, Venkat Molleti, A Veerendra Kumar, K. Saritha

Department of Electrical Engineering, Godavari Institute of Engineering and Technology(A), Rajahmundry, A.P, India.

To Cite this Article

Anapana Jeevean Reddy, Venkat Molleti, A Veerendra Kumar and K. Saritha. Bridgeless and Independent Zeta Luo Converter Based Electric Vehicle Charger. International Journal for Modern Trends in Science and Technology 2022, 9(03), pp. 243-247. <https://doi.org/10.46501/IJMTST0903037>

Article Info

Received: 28 February 2023; Accepted: 18 March 2023; Published: 19 March 2023

ABSTRACT

In this fast warming world there is a urgent of eco friendly products to stop the pollution and global warming .To stop global warming we have to immediately cease the release of carbon dioxide in to our atmosphere for that we have to modify or replace the biggest carbon releasing factors form our atmosphere one of those factors are transportation. In past century the adaptation of internal combustion engines were drastic but the those have contributed to our economies hugely but its time to replace them with more sustainable electric vehicles.Development of electric vehicles have started way back along with the development of internal combustion engines but the technologies couldn't able to catch up with that along with the need but now in the 21st century tame has arrived to switch to EV and technology has developed significantly. When we talk about technology the main infrastructure we need is charging facility. to coup up with the growing demand of EV we urgently need to update our charging facility .One of those improved chargers is BRIDGELESS ZETA LUO CONVERTER EV CHRGER, so in this report we will take a look in that

KEYWORDS: PV; EV; luo converter; DAB converter; FLC, phase shift control

1. INTRODUCTION

Electric vehicles (EVs) and photovoltaics (PVs) are two of the most promising and rapidly expanding technologies that are expected to have a significant impact on the electrical industry over the next decade. In the future transportation system, EVs will make up a large percentage due to rising worries about global warming and the unpredictability of the price and supply of fossil fuels. As the number of electric vehicles on the road increases, more and more electricity will be needed, and it's important that this power comes from renewable sources so that we can reduce our carbon footprint as much as possible. Given their widespread,

even urban, availability for production, photovoltaics (PVs) are the most ideal renewable energy source for electric vehicles. The current surge in PV usage may be attributed to the technology's capacity to meet rising energy demands at ever-decreasing costs [1-4]. The energy produced by PV is intermittent and subject to the ebb and flow of weather conditions. Therefore, an appropriate DC-DC converter that can provide regulated and controlled output from the PV system must be implemented [5, 6]. Boost converters [7], buckboost converters [8], Cuk converters [9], and SEPIC converters [10] are only some of the most common types of converters utilised in PV applications. The boost

converters' primary usage is in photovoltaic systems, although they can only increase the voltage at the input. Although buck-boost converters can do both step-down and step-up voltage conversion, their widespread use is limited by the unreliable nature of their input current. There is a larger degree of voltage stress and conduction losses in basic converters like the boost and buckboost types. Unlike buck-boost converters, the input current to a Cuk converter or SEPIC converter is continuous, allowing for a wider range of voltage reductions; nonetheless, these converters are constrained by the presence of a high level of input current ripples [11,12]. Voltage stress across the switches reduces the Luo converter's overall efficiency [13], despite its high gain, improved light load efficiency under rapidly variable line voltages, and higher voltage regulation capabilities. Picking the right controller is crucial for optimising the converter's dynamic operation, reaching unity power factor, and lowering total harmonic distortion (THD) [14]. In a fixed-range setting, PI controllers are straightforward and efficient, but they aren't well-suited to non-linear environments. The PI controller has a sluggish reaction time and suffers from peak overshoot issues when dealing with disturbances and uncertainty [15]. FLC, an intelligent controller, may get around this restriction since it is adept at addressing problems stemming from non-linearity and disturbances. In addition to enhancing dynamic performance and delivering a precise response, FLC-based systems help reduce the issue of peak overshoot [16-18]. Directly connecting an electric vehicle's battery to a dc bus exposes it to possible dangers when the load is suddenly altered. A bidirectional DC-DC converter must be built between the DC bus and EV battery to control the discharge current [19]. There are two main types of these converters, and they are categorised as either (i) isolated or (ii) non-isolated. The former have grown in popularity because of their advantageous size, price, smooth power flow management, and end-to-end isolation [20]. For high voltage gain, increasing the turns on the high-frequency transformer is one option, and there are several varieties of isolated DCDC converters available [21]. In order to charge electric vehicles, a DAB converter is used, which is a special kind of isolated bidirectional DCDC converter. The primary advantage of a DAB converter is the galvanic isolation it provides for high-frequency, soft-switched turn-on capabilities,

together with increased efficiency and reduced turn-on losses [22-25]. Diode bridge rectifiers are standard equipment in existing EV chargers (DBR). Power Quality (PQ) issues plague standard electric chargers because of the nonlinear diode bridge rectifiers used at the input. Power quality does not conform to IEC 61000-32 because of this. Consequently, this reduced the overall efficiency of the electric car because of its effect on the battery. Input current should be perfectly sinusoidal with minimal THD, as specified by the standard (THD). The nature of the mains current is non-sinusoidal, and the Total Harmonic Distortion (THD) is quite high (56.1%), as can be shown through an analysis of an EV charger's performance.

Nonlinear behaviour is caused by the Diode Bridge Rectifier, which is often found in converters; this has a significant impact on power quality indices such high Total Harmonic Distortion (THD), low Power Factor (pf), high Voltage Distortion (VD), low Displacement Factor (d_{pf}), and so on.

2. PROPOSED SYSTEM

For the purpose of designing a charger for electric vehicles, a bridgeless isolated Zeta-Luo converter is developed, which is a more efficient converter topology than the alternatives. This setup comprises mostly of two converters, Zeta and Luo, each of which makes use of just one half of the input supply at a time. The Zeta converter mostly runs on the positive half of the input supply, whereas the Luo converter fires up on the negative side. Our suggested system combines Zeta and Luo BL converters, which operate in opposite half cycles, to provide a Zeta-based BL vehicle charger. At rated voltage and throughout a broad range of key power variables, the BL converter works continuously to provide pre-PF control. The semiconductor switch S1, transformer U1, inductance Lm1, capacitor C1, and output diode Do1 all conduct throughout the positive portion of the supply circuit. Second-part-of-supply Luo converter operation is aided by semiconductor switch S2, transformer magnetising inductance Lm2, intermediate capacitor C2, and Do2 output diode.

The zeta-luo converter-based EV charger may function in one of three modes:

Mode 1: The quick response to a tap on the gate to alter setting S1 is provided during this mode. As Lm1 stores energy from its source via the diode line, its current

steadily increases. As the current travels through the second-side Lo1 output inductor, the Dp. voltage across capacitor C1 steadily drops. It would seem that the output diode Do1 is now in a non-operating condition. As of time t1, when S1 is turned off, this mode will no longer be active.

Second Mode: Diode Do1 is active while switch S1 is deactivated. Inductance in a magnetic field With the second spin of the converter, Lm1 discharges diode Do1 by discharging capacitor C1. In the constant current mode, the battery current is accessible, and the dc-link capacitor will begin charging with an inductance of Lo. The converter enters mode 3 (discontinuous operation) when the S1 key is turned off. Currents flowing through Im1 and the output inductance will cancel out, resulting in no net current. Power for battery charging is still being supplied by the capacitor Cdc. The second half of the supply, the Luo mode, follows the same pattern of actions. The zero current in the magnetic inductance is one distinction that demonstrates the Luo converter's performance in discontinuous mode.

3. PROPOSED SYSTEM MODELING:

Solar Panel Modelling

By harnessing the photovoltaic effect, as seen in Figure 2, a solar cell may produce direct electric current when exposed to sunlight. Two layers of a semi-conducting material are combined to produce this effect.

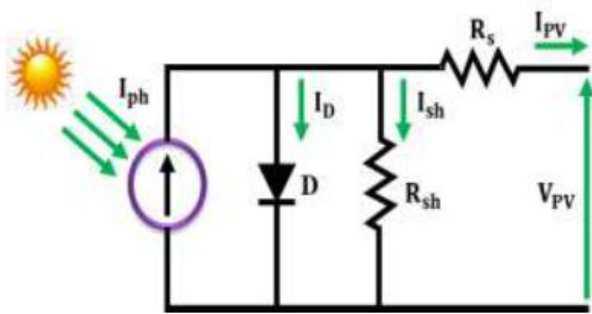

Figure 1 Equivalent circuit diagram of solar panel
Producing just a little quantity of electricity, solar cells are often not practical. A solar module, also known as a solar panel, is a collection of solar cells interconnected in series to maximise energy production. Current generated by the PV array is,

$$I_{PV} = I_{ph} - I_D - I_{sh} \quad (1)$$

$$I_{PV} = I_{ph} - I_0 \left[\exp\left(\frac{V_{PV} + I_{PV} R_s}{N_s v_{tr}}\right) - 1 \right] - \frac{V_{PV} + I_{PV} R_s}{R_{sh}} \quad (2)$$

Re-Lift Luo Converter Design and Analysis

According to Figure 3, the components of a Re-Lift Luo converter are as follows: three diodes D1, D2, and D3; three capacitors C1, C2, and C3; three inductors L1, L2, and L3; two power switches S1, S2; and an output capacitor Co.

Voltage boosting properties of capacitors C2 and C3 cause their combined voltage to be twice as high as the source voltage VPV. With the inductor L3 acting as a rung in a ladder, capacitors C2 and C3 may be connected to increase VC1.

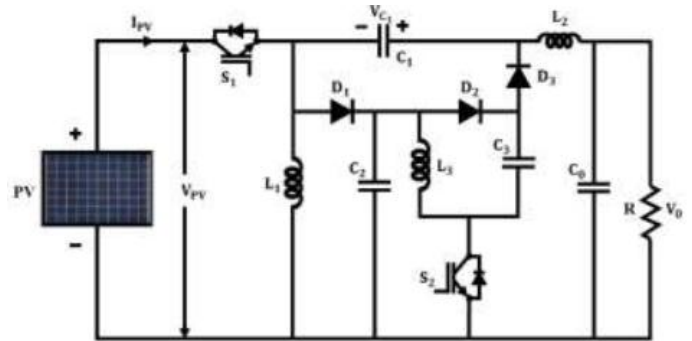

Figure 2 Circuit diagram of re-lift converter

When the power switches S1 and S2 are switched ON, the source instantaneous current $I_{PV} = i_{L1} + i_{L2} + i_{L3} + i_{C2} + i_{C3}$ flows, as shown in Figure 4. (a). In the meanwhile, the energy is stored in inductors L1 and L3. The power from the source and the storage capacity of the capacitor C1 are used to charge the inductor L2. The amount of current passing via inductors L1, L2, and L3 is amplified.

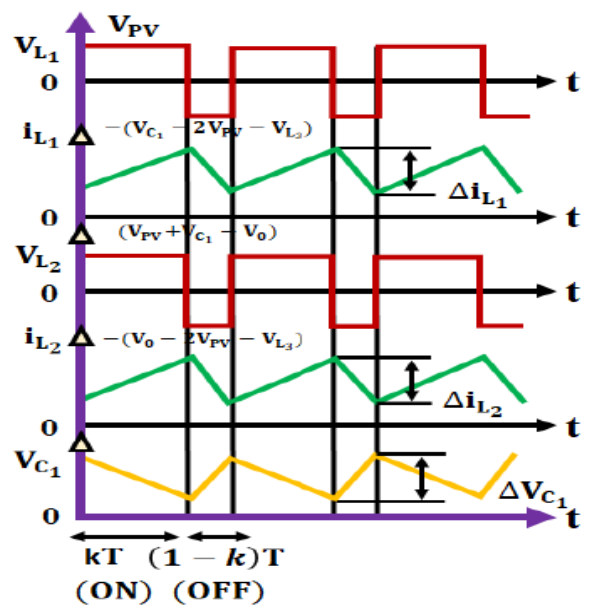

Figure 3 Re-lift Luo converter's voltage and current waveforms

The value of the inductors L_1 and L_2 are obtained from the following equations

$$L_1 = \frac{kTV_{PV}}{\Delta i_{L1}}$$

$$L_2 = \frac{kTV_{PV}}{\Delta i_{L2}}$$

The value of the capacitors C_1 , C_2 , C_3 and C_0 are obtained from the following equations,

$$C_1 = \frac{(1-k)Ti_{L1}}{\Delta V_{C1}} = \frac{(1-k)kT}{\Delta V_{C1}} I_{PV}$$

$$C_2 = \frac{(1-k)T(i_{L1}+i_{L2})}{\Delta V_{C2}} = \frac{I_0T}{\Delta V_{C2}}$$

$$C_3 = \frac{(1-k)T(i_{L1}+i_{L2})}{\Delta V_{C3}} = \frac{I_0T}{\Delta V_{C3}}$$

$$C_0 = \frac{kT^2V_{PV}}{4\Delta V_{O}L_2}$$

Since the non-linear nature of the PV output has a significant impact on the converter's voltage output, it is essential to use an efficient controller in order to maintain a constant converter output. It has been shown that FLC can improve the performance of the re-lift Luo converter, thus it has been employed to regulate the converter's operation in this study.

4. SIMULATION RESULTS

In this study, we combine a re-lift Luo converter with a DAB converter to provide a highly efficient PV-fed EV charging system. The efficiency of the suggested system is determined by MATLAB simulation.

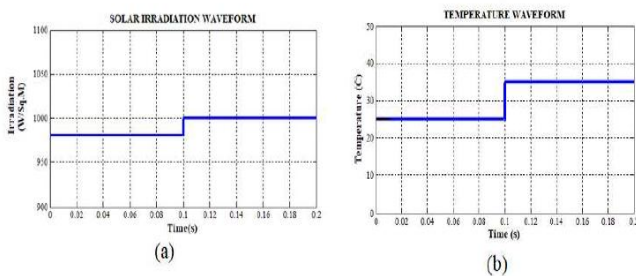

Figure 4 Waveforms of (a) Solar irradiation and (b) Temperature

Figure 5 shows how the output voltage and power of PV panels vary as a function of temperature and solar irradiance. The solar panel starts off producing 60v of power, but this quickly increases to 80v when the working conditions change (this happens in less than 0.1s). The electricity produced by PV systems similarly changes, from 1360w to 1500w, every 0.1s.

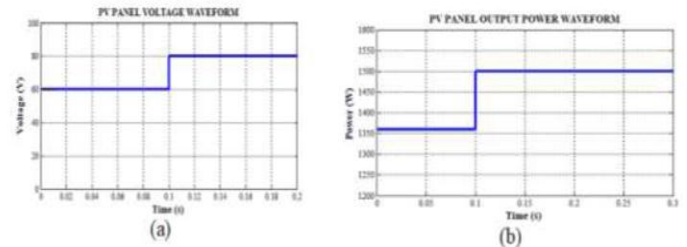

Figure 5 (a) Waveforms of PV panel voltage and (b) PV panel output power

The resulting waveform of voltage from the Re-lift Luo converter is shown in Figure 6. It has been shown that with the aid of FLC, the converter can deliver a consistent voltage output of 270v at 0.07s. The resultant output voltage does not suffer from the common issue of peak overshoot, either.

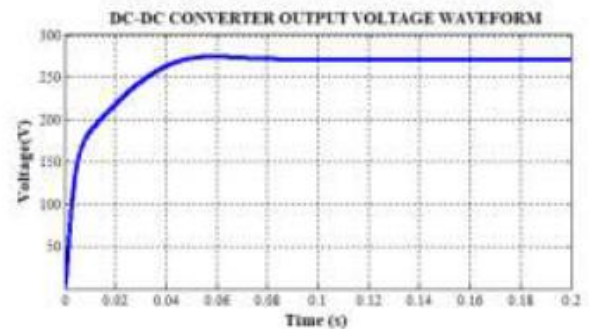

Figure 6 Re-lift Luo converter voltage output waveform

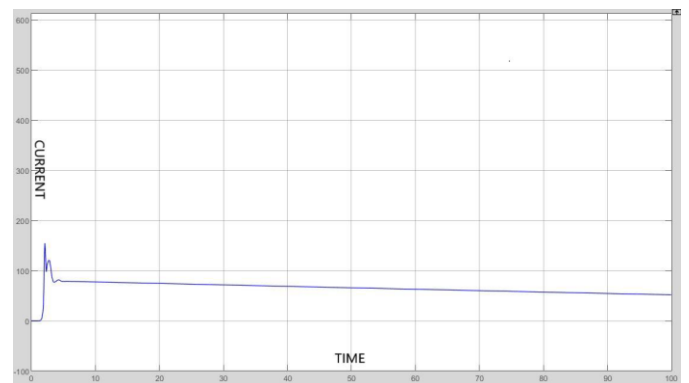

Fig 7 : Current vs Time

So as we can observe from the above figure, a low ripple current which is of high power quality has been produced.

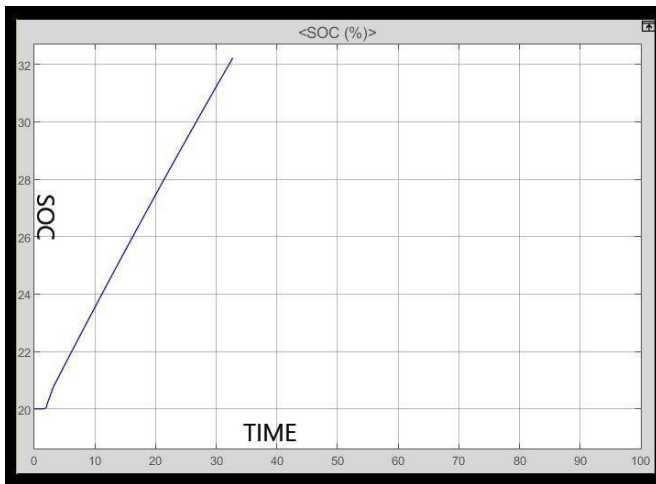

Fig 8 : State of charge

With the help of the simulation from the matlab software we got the constant current vs time graph.

We also have the SOC (state of charge) graph showing the charging of the battery from 20-32%.

We have designed the software model of the Bridgeless isolated zeta-luo Converter based EV charger through the matlab Simulink

5. CONCLUSION

To combat the worsening energy crisis and curb excessive fossil fuel use, this study proposes a method for charging electric vehicles (EVs) that makes use of renewable energy sources. A re-lift Luo converter and a DAB converter are used to increase the PV system's output and provide galvanic isolation, respectively. The PS control approach boosts the DAB converter's efficiency and expands its Zero Voltage Switching (ZVS) operating window. With an FLC technique efficiency of 96%, the re-lif Luo converter provides a consistent and controlled output.

Conflict of interest statement

Authors declare that they do not have any conflict of interest.

REFERENCES

- [1] C. Mi, M. A. Masrur, and D. W. Gao, *Hybrid Electric Vehicles: Principles and Applications With Practical Perspectives*. Hoboken, NJ, USA: Wiley, 2011.
- [2] V. Krithika and C. Subramani, "A comprehensive review on choice of hybrid vehicles and power converters,

control strategies for hybrid electric vehicles," *Int. J. Energy Res.*, vol. 42, no. 5, pp. 1–24, 2018.

- [3] Khaligh and M. D'Antonio, "Global trends in high-power on-board chargers for electric vehicles," *IEEE Trans. Veh. Technol.*, vol. 68, no. 4, pp. 3306–3324, Apr. 2019.
- [4] Emadi, Y. J. Lee, and K. Rajashekara, "Power electronics and motor drives in electric, hybrid electric, and plug-in hybrid electric vehicles," *IEEE Trans. Ind. Appl.*, vol. 55, no. 6, pp. 2237–2245, Jun. 2008.
- [5] M. Yilmaz and P. T. Krein, "Review of battery charger topologies, charging power levels, and infrastructure for plug-in electric and hybrid vehicles," *IEEE Trans. Power Electron.*, vol. 28, no. 5, pp. 2151–2169, May 2013.
- [6] M. Gray and W. Morsi, "Power quality assessment in distribution systems embedded with plug-in hybrid and battery electric vehicles," *IEEE Trans. Power Syst.*, vol. 30, no. 2, pp. 663–671, Mar. 2015.
- [7] Limits for Harmonics Current Emissions (Equipment Current per Phase), International standards IEC 61000-3-2, 2000.
- [8] L. Petersen and M. Andersen, "Two-stage power factor corrected power supplies: The low component-stress approach," in *Proc. IEEE APEC*, 2002, vol. 2, pp. 1195–1201.
- [9] J. Duarte, L. R. Lima, L. Oliveira, M. Mezaroba, L. Michels, and C. Rech. "Modeling and digital control of a single-stage stepup/downisolated PFC rectifier," *IEEE Trans Ind. Informat.*, vol. 9, no. 2, pp. 1017–1028, May 2013.
- [10] F. Musavi, M. Edington, W. Eberle, and W. G. Dunford, "Evaluation and efficiency comparison of front end AC-DC Plug-in hybrid charger