



Energy Management with PV Integrated Battery Energy Storage System using ANN Technique

Eepuri Manikanta, Vullingala D V Naga Sathya Sai Prabhu, Meripe Rahul, K. Sravani

Department of Electrical Engineering, Godavari Institute of Engineering and Technology(A), Rajahmundry, A.P, India.

To Cite this Article

Eepuri Manikanta, Vullingala D V Naga Sathya Sai Prabhu, Meripe Rahul and K. Sravani. Energy Management with PV Integrated Battery Energy Storage System using ANN Technique. International Journal for Modern Trends in Science and Technology 2022, 9(03), pp. 236-242. <https://doi.org/10.46501/IJMTST0903036>

Article Info

Received: 28 February 2023; Accepted: 18 March 2023; Published: 19 March 2023

ABSTRACT

In order to mitigate the power fluctuations caused by PV panel characteristics and solar radiation, it is usual practise to include battery storage into PV systems. The bus voltages in photovoltaic battery systems must be stabilised while allowing for a high degree of discretion in the management of power flows. This paper's goal is to propose a comprehensive control and power management system (CAPMS) for AC and DC bus-based PV-battery hybrid microgrids operating in both grid-connected and islanded modes. The proposed investigation contrasts PI controllers with artificial neural networks (ANN). Regulators keep an eye on both the power supply and the waves. The task was completed using the Matlab simulink application.

KEYWORDS: Battery storage, Artificial Neural Network, PV-battery systems, PI Controller.

1. INTRODUCTION

Microgrids are small, decentralised energy networks that may operate autonomously from both the larger power grid and other microgrids. According to the Microgrid Exchange Group of the US Department of Energy, the following skills are necessary: A microgrid is a small electrical grid that operates within clearly defined geographic boundaries, connecting and containing loads and distributed energy resources. A microgrid is essentially an independent grid inside a bigger grid. Microgrids may switch between grid-connected and island modes, depending on their needs.

In order for a microgrid to meet the electrical power demands of its consumers, it must have access to a producing source. Due to the microgrid's age, it has often received its power from fossil fuel sources located

"beyond the metre," such as gas-powered plants. However, many of the microgrids that are now being developed obtain their electrical supply from a mix of solar energy and battery storage because of the dropping cost of solar energy and the environmental advantages of transitioning away from the production of electricity using fossil fuels. To begin, it's important to note that this is a kind of local energy, meaning that it serves local customers. This is one of the main differences between microgrids and the enormous centralised grids that have provided the bulk of our nation's electricity for the previous century. Power plants can transmit electricity across long distances thanks to transmission and distribution lines that link to major grids. Long-distance power transmission is inefficient due to the fact that some of the energy is wasted along the way. This loss may be as high as 15%

of the total. A microgrid sidesteps this inefficiency by generating power in close proximity to the people it serves. Microgrids often have their power sources close by or within the structure itself, with the instance of solar panels placing them on the rooftop.

2. SOLAR ENERGY

2.1 Introduction

One method of generating energy is by the use of solar cells, which are photovoltaic semiconductors that convert solar radiation into DC power. Photovoltaic energy is generated using solar panels comprised of many individual cells, each of which contains a photovoltaic material. Monocrystalline silicon, polycrystalline silicon, amorphous silicon, cadmium telluride, and copper indium selenide/sulfide are only some of the types of silicon that may be used in photovoltaics [1]. However, amorphous silicon, another form of silicon, is also useful. Other forms of silicon, such as amorphous silicon, may also be put to use. Rising demand for solar and other renewable energy sources has led to significant improvements in solar cell and photovoltaic array production over the last several years.

Solar photovoltaic generates electricity in over 100 nations as of 2010, and is the world's fastest growing power-generation technology, but accounting for only a small portion of the 4800 GW total global power-generating capacity from all sources. Grid-connected PV System capacity expanded by 60% of annually average of 2004 to 2009 is 21GW. Building Combined Photovoltaics or BIPV for short are installations that are either ground-mounted or sometimes integrated with farming and grazing embedded into the roof or walls of a building. An extra 3–4 GW comes from off-grid PV.

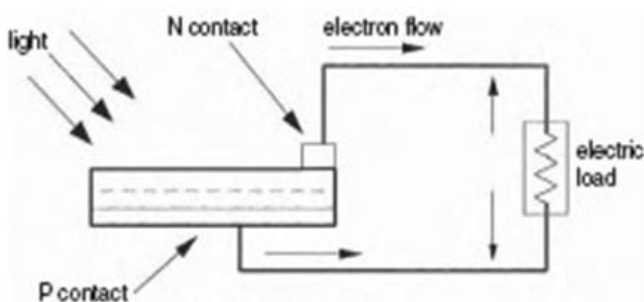

Fig 2.1: PV converts the photon energy into voltage across the p-n junction

Since the invention of the first solar cells, advances in technology and greater efficiency in production have led to a steady decline in the price of photovoltaics. Positive feed-in rates for solar-generated power and other financial incentives have helped spread the use of solar photovoltaics around the globe.

Light causes a material to produce a voltage via what is called the photovoltaic effect (or a corresponding electric current). It is important to distinguish between the photovoltaic effect and the photoelectric effect, despite their close relationship. In the photoelectric effect, electrons are emitted from the surface of a substance when it is subjected to radiation of a high enough energy. What sets the photovoltaic effect apart is that the created electrons are transferred across bands inside the material (from the valence to the conduction bands), resulting in a voltage increase between two electrodes. These cells were given their name since the sun is the most common source of radiation employed in photovoltaic applications. P-n junction solar cells generate current when exposed to light because the electric field present in the depletion region sweeps the excited electrons and residual holes in opposite directions. In Figure 2 we can observe this behaviour clearly. In 1839, Alexandre-Edmond Becquerel is credited with being the first to notice the photovoltaic effect. In October of 2010, Canada's 80 MW Sarnia Photovoltaic Power Plant was the biggest PV power plant in the world. There are several more major PV power plants, such as Spain's 60 MW Olmedilla Photovoltaic Park, Germany's 54 MW Strasskirchen Solar Park, Germany's 53 MW Lieberose Photovoltaic Park, Spain's 50 MW Puertollano Photovoltaic Park, Portugal's 50 MW Moura Photovoltaic Park, and so on (Germany, 40 MW).

2.1.1 In Buildings:

Photovoltaic arrays are often linked with buildings, either because they are installed on or next to the ground, or because they are incorporated into the design of the building itself. Arrays are often installed as an afterthought in preexisting buildings, often affixed to the existing roof or the existing walls. Alternatively, a cable may be run from an array located elsewhere and linked to the building in order to provide energy to the building. The vast majority of Germany's solar PV capacity, over 8,500 MW, was added to roofs that year.

2.1.2 In Transport:

Solar photovoltaics (PV) have been utilised for quite some time to generate electricity in space. Motive power generation from PV is uncommon in transportation applications, but its use as an auxiliary power source in vehicles like boats and automobiles is on the rise. While the power and usefulness of a standalone solar car are questionable, solar-charged vehicles can get you where you need to go. Solar-powered cars have already been shown out.

2.1.3 Standalone Devices:

Before approximately a decade ago, PV was often employed to power calculators and other novelty gadgets. These devices can now run for years without needing new batteries because to advancements in integrated circuits and low-power LCD screens, which has reduced the need for PV. However, in regions where grid energy is unaffordable owing to high connection prices, solar-powered remote fixed devices have lately gained appeal. There are a wide variety of applications for this technology, including water pumps, parking metres, emergency phones, garbage compactors, temporary traffic signs, and remote guard posts and signals.

2.1.4 Rural Electrification:

Since many rural villages in developing nations are more than five kilometres away from the nearest electricity line, photovoltaics have become more popular. Solar-powered LED lights have been distributed by an Indian government scheme to replace kerosene lamps in rural areas. The cost of a few months' supply of kerosene was compared to the cost of the solar lights. Cuba plans to provide solar electricity to remote areas that now lack access to the grid. While there is a clear justification for going solar in these areas due to the social costs and benefits, the lack of profitability may restrict such initiatives to purely altruistic ones.

2.1.5 Solar Roadways:

Since roadways are often unobstructed to the sun and represent nearly the proportion of land area required to replace other energy sources with solar power, a 45 mile (72 km) length of roadway in Idaho is being used to investigate the idea of embedding solar panels into the road surface. As a result of its low environmental

impact and low maintenance requirements, solar energy has recently emerged as the dominant technological platform. To improve energy efficiency, solar systems have recently been installed in highways.

2.1.6 Solar Power Satellites:

Spacecraft that harvest solar energy on a massive scale have been the focus of design studies for decades. Peter Glaser, formerly of Arthur D. Little Inc, initially proposed the idea in the 1960s; NASA conducted a lengthy series of technical and economic feasibility studies beginning in the 1970s; and the notion has lately seen renewed attention in the early 2000s. For such satellites, the problem of launch cost seems to be the most relevant issue from a practical economic aspect. Space-based assembly procedures still need to be developed, although this seems like a lesser hurdle than the initial investment. As the price of solar panels drops or their efficiency increases, these will go down.

2.2 Solar cell:

One way that sunlight may be converted into energy is via the use of a solar cell, which is a semiconductor device that exploits the photovoltaic effect. In the solar industry, solar modules are more usually referred to as solar panels, however they are really composed of cell assemblies. These solar modules generate solar electricity, which is one kind of renewable energy.

The PV potential originates from the disparity in the Fermi levels (chemical potentials) of the electrons in the two separated materials. When they're connected, a new thermodynamic equilibrium is established at the junction. Such a balance is possible only when the Fermi levels of the two substances are equivalent. The electrons flow from one material to another until the voltage difference between them is equal to the difference at the Fermi level. This potential is what powers the photocurrent in the PV system. Although the word is usually solely used to describe the process of harnessing solar electricity, photovoltaics is really the scientific study of how photovoltaic cells may be utilised to convert light into usable energy. Photovoltaic cells are those used when the light source isn't always the sun. These are used to either detect or quantify the intensity of light or other forms of electromagnetic radiation in the visible spectrum.

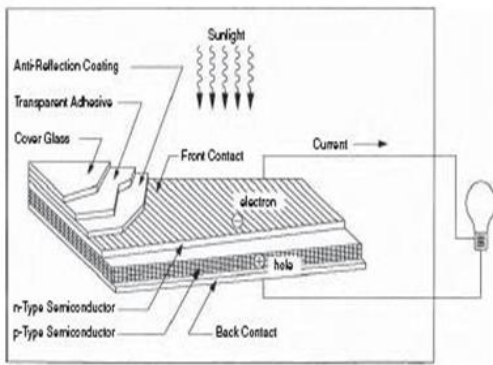

Fig 2.2: Basic construction of PV cell

Equivalent electrical circuit of a Battery:

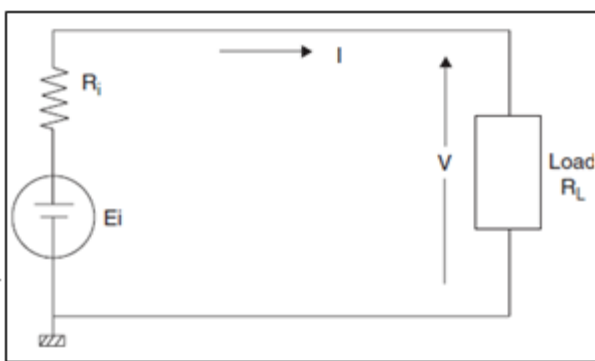

Fig 2.3: Equivalent electrical circuit of a Battery

3. PI CONTROLLER

PI controllers, or proportional-integral controllers, are a form of feedback controller used in control engineering to identify the optimal driving strategy for a plant. This kind of controller incorporates both the error, or the difference between the actual output and the goal value, and its integral into its calculations. One subset of PID controllers does not take into account the derivative (D) of the error signal.

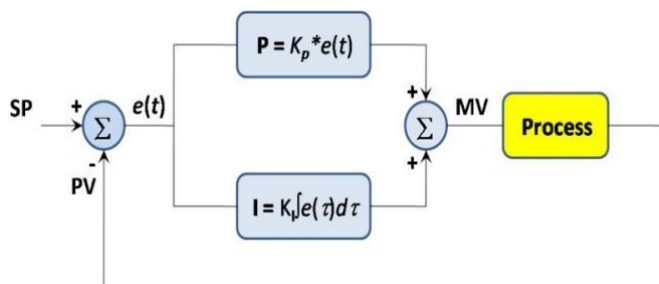

Fig.3.1: Block diagram of a PI controller

Integration of integral control action transforms the proportional controller into a high-order system. If K_p

is very large, the control system may become unstable because the roots of the characteristic equation may have a positive real component. This is because it's possible that the roots of the characteristic equation will include a real-valued positive integer. When applied to a system subject to a wide range of inputs, proportional control tends to stabilise it, but integral control has the ability to significantly decrease or even eliminate steady-state error. There is a general trend toward less overshoot and faster reaction times as T_i increases.

4. ARTIFICIAL NEURAL NETWORKS

To put it simply, Artificial Neuronal Networks are simplified digital representations of the brain's neural architecture. The brain is primarily an experiential learner. The results show that load problems that are too difficult for today's computers to tackle may be solved by compact, low-power devices. The use of brain models holds up hope for a less complex approach to creating technological answers. It is expected that these computer approaches influenced by biology will be the next big thing. Simple animal brains can do tasks that computers can't even begin to mimic just now. Computers excel at routine tasks like maintaining an accounting system or calculating complicated formulas. However, computers struggle to recognise even the most basic patterns, much less generalise previous actions into future actions. Developments in biological study have recently offered hope for a first glimpse into the workings of the mind in its natural state. This study demonstrates that the brain organises information into patterns. Some of these patterns are quite intricate, allowing us to identify certain faces from a variety of perspectives. A new area of computer science has developed around the concept of storing data as patterns, applying those patterns to problems, and finally achieving a solution. Instead of using standard programming, researchers in this discipline build massively parallel networks and teach them to solve problems. Words like "behave", "respond", "self-organize", "learn", "generalise", and "forget" are used in this discipline that are considerably different from the language of "conventional computing". The term "neural network" (NN) refers to the mathematical model or computer model that is based on biological

brain networks; this is what distinguishes it from "artificial neural network" (ANN). It uses a connectionist method of computing and is composed of a network of artificial neurons. The learning phase of an ANN often involves the system adapting its structure in response to incoming data from the outside or from inside the network itself. In a nutshell, neural networks are used to describe statistical data in a way that is not linear. They are useful for discovering patterns in data and modelling intricate connections between inputs and outcomes. Like the huge network of neurons in the human brain, a neural network is made up of a collection of nodes that communicate with one another.

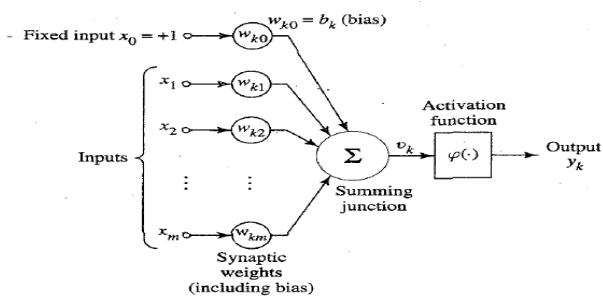

Fig 4.1: Artificial Neural Networks

5. SIMULATION RESULTS

Project Background

- A DC/DC boost converter is used in this project to connect the PV array to the DC bus.
- A bidirectional DC/DC converter regulates the charging and discharging of the batteries in the battery bank.
- For the purpose of linking the DC and AC systems, a central inverter has been set up.
- The DC load block often stands in for the many loads that connect to the DC bus.
- CAPMS chooses the operating modes of PV array & battery (charging, discharge mode) & delivers correct reference values to controllers based on PV output power, battery state of charge, battery power limit, and AC loads. In order to maintain a stable power supply, CAPMS will use one of many possible control strategies for the converters.

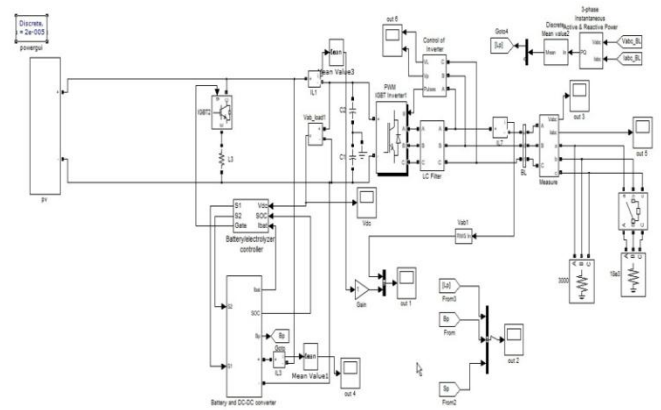

Fig.5.1 Proposed Model

- a) Case1:
 Initialload -10000watt
 Extraload - 4000watt
 Battery Specifications:
 1. 200volts,
 2. 6.5AH
 3. Nickel-Metal Hydrate Battery

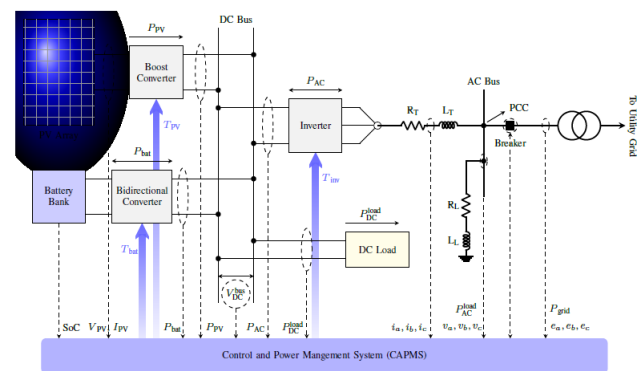

Fig 5.2 Simulation Model of CAPMS

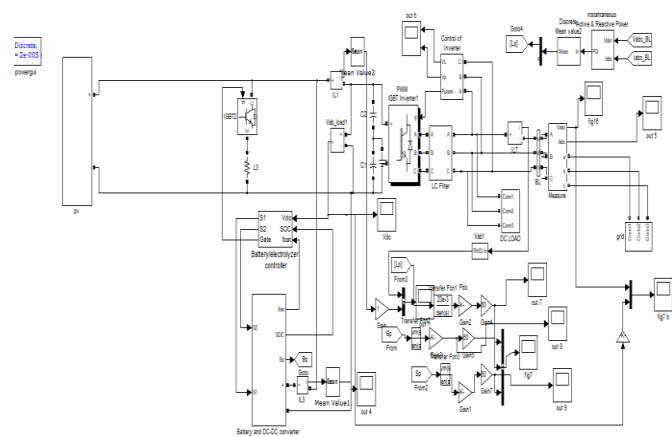

Fig 5.3 Simulation Model of Proposed System with ANN

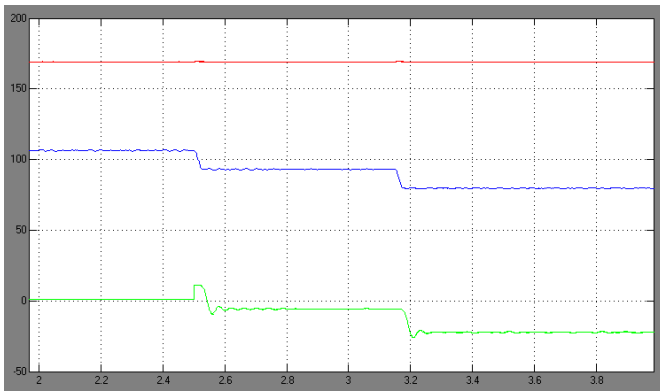

Fig 5.4 Simulation result with PWM (PI) control

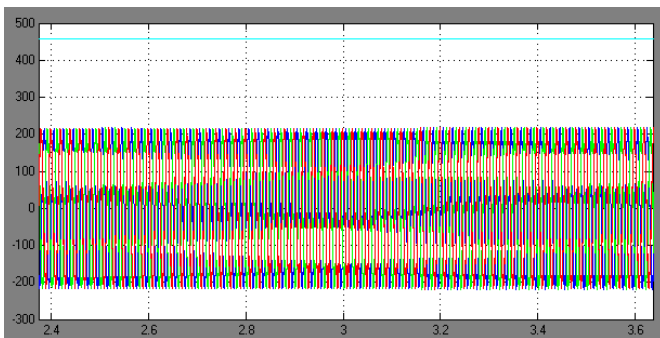

Fig 5.5 AC Line Voltage and Phase Voltage given by the inverter

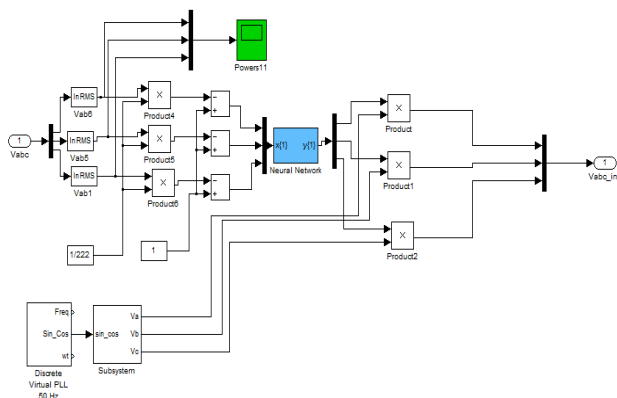

Fig 5.6 Inverter control with ANN control

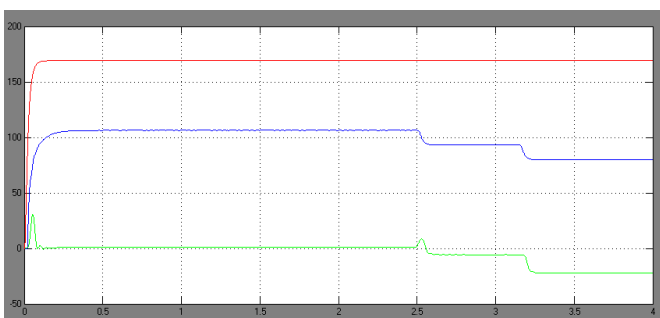

Fig 5.7 Simulation result with ANN control

6. CONCLUSION

In this study, we offer a control and power management system for a PV battery system operating in isolated mode, using both DC and AC buses. The CAPMS, thus, has complete command over both the DC and AC buses while operating in islanded mode. The described CAPMS can efficiently and flexibly regulate power flows in converters of any size. As an added bonus, CAPMS keeps the system running smoothly even if the PV array goes down due to a defect or if the power fluctuates because to erratic irradiance. To regulate the hybrid system's power flow and the DC and AC bus voltages, the CAPMS optimises the reference values for each unit and transmits PWM (pulse width modulation) signals to the inverter and converter. Using PI and ANN controllers, the proposed CAPMS uses a tried-and-true technique. When compared to more traditional approaches, the outcomes produced by ANN controllers are superior.

Conflict of interest statement

Authors declare that they do not have any conflict of interest.

REFERENCES

- [1] Omar, R. Rahim, N.A. "New Control Technique Applied in Dynamic Voltage Restorer for Voltage Sag Mitigation" Industrial Electronics and Applications, 2009. ICIEA 2009.4th IEEE Conference.
- [2] Faisal, M.F. "Power Quality Management Program: TNB's Experience", Distribution Engineering, TNB 2005.
- [3] Dinesh, Lakhinana, Harish Sesham, and Vasupalli Manoj. "Simulation of D-Statcom with hysteresis current controller for harmonic reduction." Emerging Trends in Electrical Engineering and Energy Management (ICETEEEM), 2012 International Conference on. IEEE, 2012.
- [4] Wahab, S.W. Yusof, A.M. "Voltage Sag Mitigation Using Dynamic Voltage Restorer (DVR) System, ELEKTRIKA, 8(2),2006, 32-37. IEEE Standard Board (1995), "IEEE Std. 1159-1995", IEEE Recommended Practice for Monitoring Electric Power Quality". IEEE Inc. New York.
- [5] Kim H. "Minimal Energy Control for a Dynamic Voltage Restorer", In proceedings of the Power Conversion Conference, Osaka, Japan, 2002, pp. 428-433.
- [6] V.K. Ramachandaramurthy, A. Arulampalam, C.Fitzer, C. Zhan, M. Barnes and N. Jenkins "Supervisory control

- of dynamic voltage restorers "IEE Proc.-Gener. Transm.Distrib. Vol. 151, No. 4, pp. 509- 516, July 2004.
- [7] P. Boonchiam and N. Mithulanathan, "Understanding of Dynamic Voltage Restorers through MATLAB Simulation," *Thammasat Int. J. Sc. Tech.*, Vol. 11, No. 3, July-Sept 2006.
- [8] V. B. Venkateswaran and V. Manoj, "State estimation of power system containing FACTS Controller and PMU," 2015 IEEE 9th International Conference on Intelligent Systems and Control (ISCO), 2015, pp. 1-6, doi: 10.1109/ISCO.2015.7282281.
- [9] Manohar, K., Durga, B., Manoj, V., & Chaitanya, D. K. (2011). Design Of Fuzzy Logic Controller In DC Link To Reduce Switching Losses In VSC Using MATLAB-SIMULINK. *Journal Of Research in Recent Trends*.
- [10] Manoj, V., Manohar, K., & Prasad, B. D. (2012). Reduction of switching losses in VSC using DC link fuzzy logic controller *Innovative Systems Design and Engineering ISSN, 2222-1727*.
- [11] Nise, N. S. "Control Systems Engineering" 5th Edition, John Wiley & Son, Inc. 2008
- [12] Mattavelli, P. Rossetto, L. Spiazzi, G. Tenti, P. "General-Purpose Fuzzy Controller for DC-DC Converter" *IEEE Transactions on Power Electronics*, Vol. 12, No. 1, January 1997.
- [13] Nemati, M. Yousefian, H. A. Afshari, R. "Recognize The Role of A DVR in Power Systems" *International Journal of Recent Trends in Engineering*, Vol 2, No. 7, November 2009.
- [14] Benachaiba, C. Ferdi, B. "Voltage Quality Improvement Using DVR", *Electrical Power Quality and Utilization, Journal Vol. XIV, No. 1, 2008*.
- [15] Dinesh, L., Harish, S., & Manoj, V. (2015). Simulation of UPQC-IG with adaptive neuro fuzzy controller (ANFIS) for power quality improvement. *Int J Electr Eng*, 10, 249-268.
- [16] Moulali, S., Vijay Muni, T., Bala Subrahmanyam, Y., & Kesav, S. (2018). A flying capacitor multilevel topology for pv system with apod and pod pulse width modulation. *Journal of Advanced Research in Dynamical and Control Systems*, 10(2), 96–101.
- [17] Srikanth, M., Vijay Muni, T., VishnuVardhan, M., & Somesh, D. (2018). Design and simulation of PV-wind hybrid energy system. *Journal of Advanced Research in Dynamical and Control Systems*, 10(4), 999–1005.
- [18] Vijay Muni, T., Sai Sri Vidya, G., & Rini Susan, N. (2017). Dynamic modeling of hybrid power system with mppt under fast varying of solar radiation. *International Journal of Applied Engineering Research*, 12(Special Issue 1), 530–537.
- [19] Sudharshan Reddy, K., Sai Priyanka, A., Dusarlapudi, K., & Vijay Muni, T. (2019). Fuzzy logic based iUPQC for grid voltage regulation at critical load bus. *International Journal of Innovative Technology and Exploring Engineering*, 8(5), 721–725.
- [20] Ilahi, S., Ramaiah, M. S., Muni, T. V., & Naidu, K. G. (2018). Study the performance of solar PV array under partial shadow using DC- DC converter. *Journal of Advanced Research in Dynamical and Control Systems*, 10(4 Special Issue), 1006–1014.