



# Embroidered Multiband Body-Worn Antenna For GSM/PCS/WLAN Communications

Karthika Rajan | Akhil Kumar

Department of ECE, Mangalam College of Engineering, Ettumanoor, Kerala, India

## To Cite this Article

Karthika Rajan and Akhil Kumar. Embroidered Multiband Body-Worn Antenna For GSM/PCS/WLAN Communications. International Journal for Modern Trends in Science and Technology 2022, 8(S09), pp. 52-56. <https://doi.org/10.46501/IJMTST08S0913>

## Article Info

Received: 26 May 2022; Accepted: 24 June 2022; Published: 30 June 2022.

## ABSTRACT

*In this paper, a practical study and simulations about the transmission lines and microwave filters metamaterials at the base of the resonance elements is proposed. The Split Ring Resonator (SRR) and the Complementary SRR (CSRR) are coupled with the transmission lines in order to show the electromagnetic properties of metamaterials devices, and their transmission and reflection characteristics for each structure. A novel concept of a compact dual band rejection microwave filter with a high selectivity in the frequency and miniature size is designed. The theory of metamaterials, the NRW approach (Nicolson-Ross-Weir) are briefly introduced.*

**KEYWORDS:** Metamaterials, SRR, CSRR

## 1. INTRODUCTION

Metamaterials are artificial pseudo-homogeneous structures with electromagnetic properties not found in nature. The particular property that renowned metamaterials is the possibility of having a negative permeability and permittivity simultaneously. At microwave frequencies, these structures have a structuration where the electrical length of the unit cell is much smaller than the wavelength of the guided wave. The electromagnetic properties of these hypothetical media were systematically studied by the Russian physicist VICTOR.G. Veselago in 1968, he has also developed the theory of left-handed propagation in such environments. In 1999, J.PENDRY presented a resonant double ring and it is considered as the basic element of the first metamaterial realized.

The type of metamaterial transmission line resonance can be achieved by loading a host line with a SRR and

inductive shunt elements or alternatively by loading a host line with CSRR and capacitive elements in series. The CSRR is a double counterparty of SRR; they are formed to show a left handedness in planar transmission media by etching these resonators in the ground plane other microstrip transmission line. Due to the presence of CSRR, inhibition of the propagation of the signal is given to a resonance frequency as a narrow band; this phenomenon interprets the negative effective permittivity of the medium. The capacitive series gaps are added to the structure, in order to obtain the negative permeability as well as a bandwidth with the wave propagation in the left-handed. Therefore, the transmission lines based on SRR and CSRR act as frequency selective structures with the dimensions of the unit cell electrically small.

The metallic wires or the conductive strips of the transmission line have a negative permittivity  $\epsilon < 0$ , and

the periodic array of SRR has a negative permeability  $\mu < 0$  around the resonant frequency. By bringing the two networks in a composite structure, this medium then gives us a negative refractive index  $n < 0$  in the vicinity of the resonance frequency of the SRRs. The electromagnetic properties of the SRRs having been analyzed, this analysis shows that the SRR behaves LC resonator which can be excited by an external magnetic flux, having a strong diamagnetism above the first resonance. The CSRR behaves essentially as an electric dipole which can be energized by an axial electric field. The purpose of this article is to make a comparison between several structures developed by a new approach to the design of metamaterials filters, where the microstrip line is loaded by SRR and CSRR, in order to achieve miniaturization, as well as performance and selectivity improved considerably.

## 2. SRR AND CSRR

Recently, there has been a growing interest in using the split-ring resonator (SRR) and the complementary split-ring resonator (CSRR) as constituent particles for the design of novel planar microwave components, in particular, band-pass and band-reject filters. The advantage of using this kind of resonators for filter design is that they are significantly smaller in size than conventional resonator structures (generally less than one-tenth of a wavelength) enabling the design of very compact filters. It has been demonstrated that when loaded with SRRs, microstrip lines behave as high-Q, band-reject filters with deep stop-bands in the vicinity of their resonant frequencies due to the generation of an effective medium with negative permeability. Similarly, a CSRR loaded microstrip line, which can be considered as the dual of the SRR-loaded line, inhibits signal propagation over a narrow band around the resonant frequency of the CSRRs. However, as a result of the dual relationship between the SRR and CSRR, this sort of signal inhibition is due to the presence of an effective medium with negative permittivity over the stop-band. In either case, previously propagating waves (in the absence of SRRs or CSRRs) become evanescent waves as a result of the impenetrable nature of the single-negative (SNG) medium.

A single cell SRR has a pair of enclosed loops with splits in them at opposite ends. The loops are made of

nonmagnetic metal like copper and have a small gap between them. The loops can be concentric or square or omega and gapped as needed. Due to splits in the rings the structure can support resonant wavelengths much larger than the diameter of the rings. This would not happen in closed rings. The small gaps between the rings produces large capacitance values which lower the resonating frequency. The dimensions of the structure are small compared to the resonant wavelength. This results in low radiative losses, and very high quality factors. Split ring resonators (SRRs) consist of a pair of concentric metallic rings, etched on a dielectric substrate, with slits etched on opposite sides. These resonators have been used for the synthesis of left handed and negative refractive index media, where the necessary value of the negative effective permeability is due to the presence of the SRRs. When an array of electrically small SRRs is excited by means of a time varying magnetic field, the structure behaves as an effective medium with negative effective permeability in a narrow band above SRR resonance. SRRs have also been coupled to planar transmission lines, for the synthesis of transmission line metamaterials.

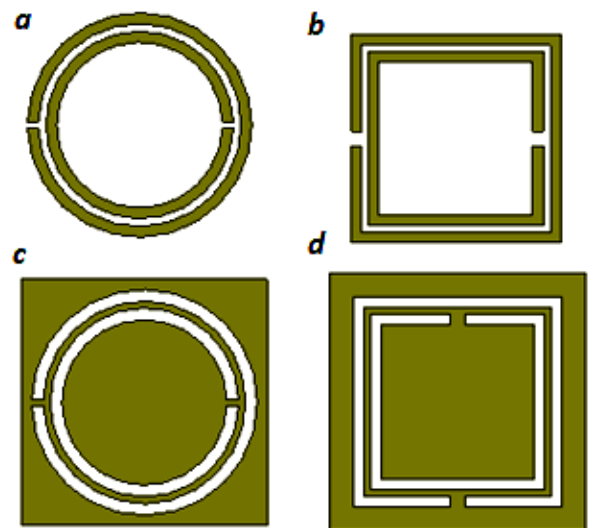

Fig.1 Schematic view of (a) circular SRR (b) square SRR (c) circular CSRR (d) square CSRR

## 3. SRR BASED BAND-REJECT FILTERS

A microstrip transmission line generates magnetic field lines that close upon themselves around the line. If two arrays of SRRs are placed closely at both sides of the central line, a significant portion of the magnetic field

lines induced by the line is expected to cross the SRRs with the desired polarization giving rise to a negative- $\mu$  effect over a narrow band around the resonant frequency of the individual SRRs. Hence, inhibition of signal propagation over this band can be achieved.

#### 4. CSRR BASED BAND-REJECT FILTERS

The CSRR is considered as the dual counterpart of the conventional SRR. Thus, a time-varying electric field having a strong component in the axial direction gives rise to an effective- $\epsilon$  medium. Considering this fact in mind, working mechanism of a CSRR-based band-reject filter be explained as follows: a microstrip transmission line electric field lines that originate from the central strip and terminate perpendicularly on the ground plane. Due to the presence of dielectric substrate, field lines are tightly concentrated just beneath the central conductor and the electric flux density reaches its strongest value in the vicinity of this region. Therefore, if an array of CSRRs is etched on the ground plane aligned with the strip, a strong electric coupling with the desired polarization is expected.

#### 5. MODELING OF THE STRUCTURES CSRR / SRR

Based on the approach of the type metamaterial transmission lines the implementation of these lines is done either by means of SRR or their or both within the same structure.

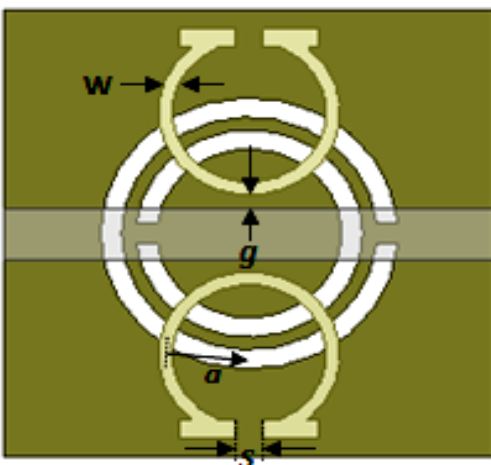

Fig.2 Schematic view of microstrip line loaded with Omega SRR coupled with SRR etched on a dielectric substrate

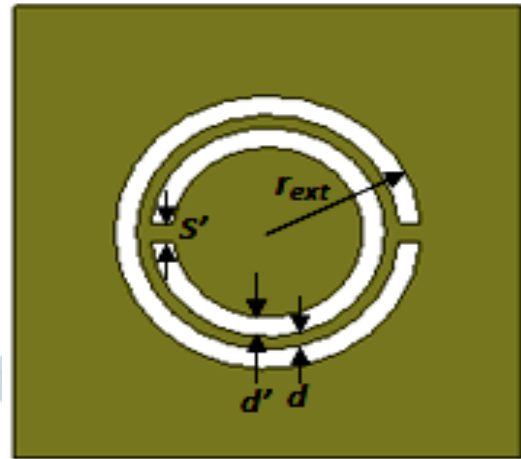
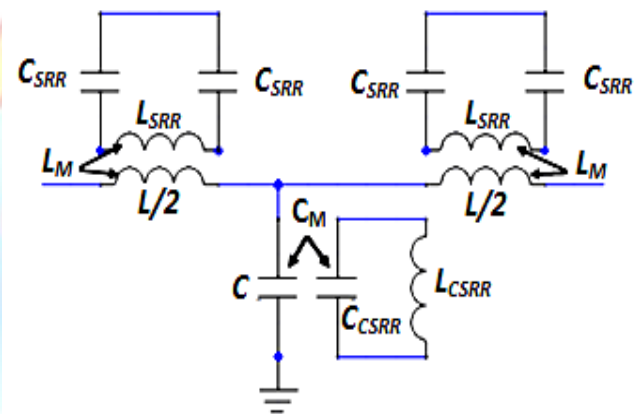

Fig.3 Schematic view of bottom surface of the CSRR etched on the ground plane

The model of the equivalent circuit is depicted in figure below.



Where L and C are the inductance and capacitance respectively per unit length of the microstrip line. The single SRRs on the top are inductively coupled with the line through the mutual inductance  $L_M$  while the CSRR on the ground plane is capacitively coupled to the line through a mutual capacitance  $C_M$ .

#### 6. SOME METAMATERIAL DUAL BAND REJECTION FILTER DESIGN

The filter is composed of two unit cells having two single Omega SRR coupled with CSRR etched on the ground plane. The effective refractive index must be extracted from the complex coefficients of transmission and reflection of the structure. The structure has been simulated using the Finite Element Method (FEM)-based High-Frequency Structure Simulator (HFSS) commercial software of Ansoft Corporation. The conventional procedure for extraction of the effective parameters is

known as the method of Nicholson-Ross-Weir (NRW). NRW method is simply based on the classic calculation of interference giving the transmission and reflection of a layer of material according to its effective index, its effective impedance and its thickness. By reversing these formulas, the value of  $n_{eff}$  is deduced according to the thickness of the simulated layer, the transmission  $t'=S_{21}$  and reflection  $r=S_{11}$  coefficient. The equation for finding effective refractive index using the method of Nicholson-Ross-Weir is shown below:

$$Re(n_{eff}) = \pm Re \left( \frac{\arccos \left( \frac{1}{2t'} [1 - (r^2 - t'^2)] \right)}{kd} \right) + \frac{2\pi m}{kd}$$

where 'm' is an integer.

For the simulation, a Rogers RT/duroid substrate with a thickness of 1.28mm and a dielectric constant  $\epsilon_r=10.2$  is used. Each structure consists of a microstrip line in width of conductive strip 0.8 mm corresponding to a characteristic impedance of 50  $\Omega$ . The dimensions are as follows:  $a=1.2\text{mm}$ ;  $s=0.4\text{mm}$ ;  $g=0.2\text{mm}$ ;  $w=0.2\text{mm}$ ;  $r_{ext}=2.12\text{mm}$ ;  $s'=0.3\text{mm}$ ;  $d'=0.3\text{mm}$ ;  $d=0.2\text{mm}$ .

### 7. DUAL-BAND-REJECTION FILTER STRUCTURE

A) *Transmission line loaded with two Omega SRRs coupled with CSRR etched on the ground plane*

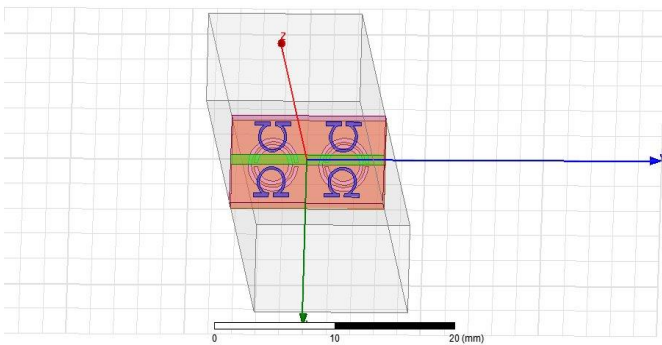

Transmission Characteristics:

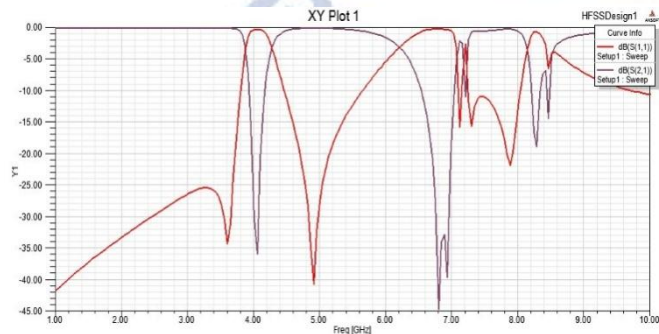

Effective Refractive Index:

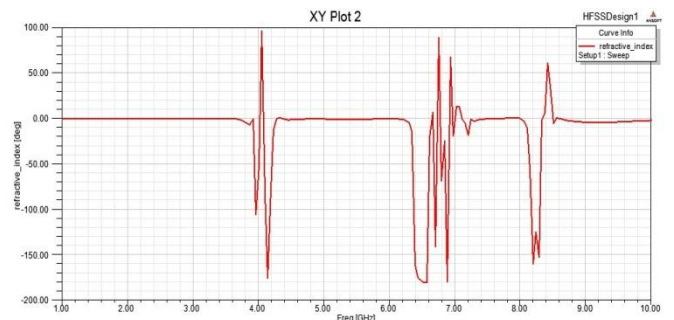

B) *Transmission line loaded with single Omega SRR coupled with CSRR etched on the ground plane*

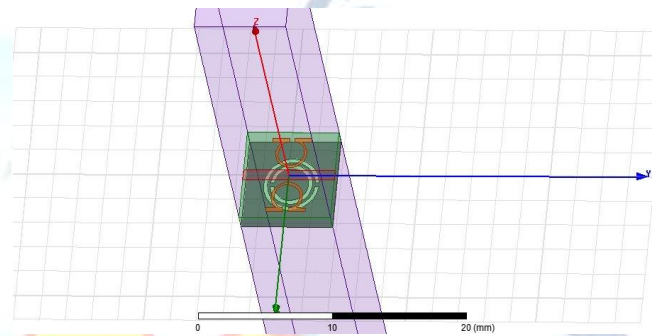

Transmission Characteristics:

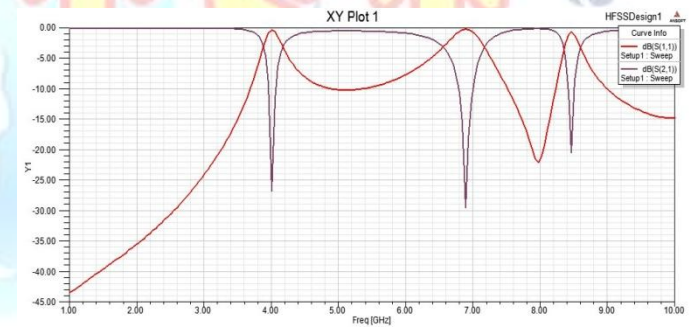

Effective Refractive Index:



### C) Microstrip Transmission Line

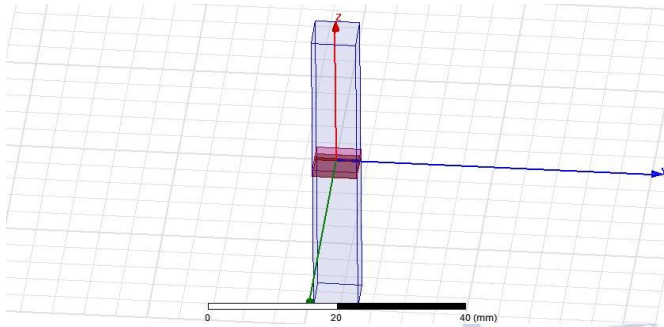

Transmission Characteristics:

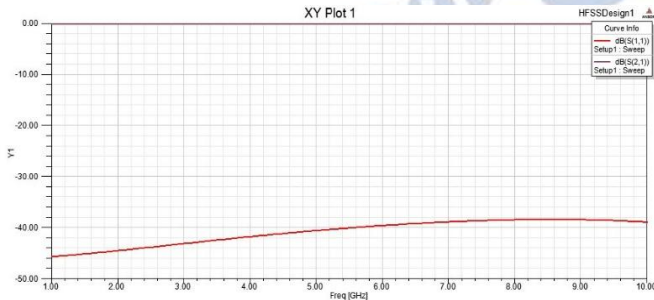

Effective Refractive Index:

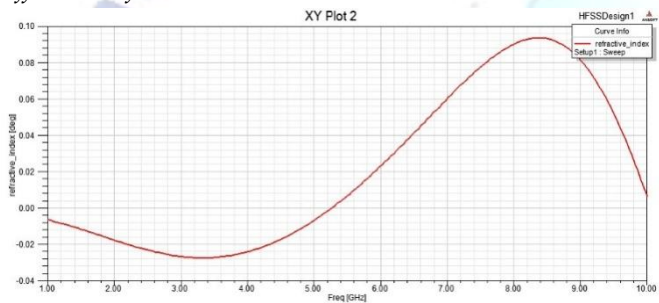

## 8. RESULTS

The result of simulation shows that:

1) for a microstrip transmission line loaded with two Omega SRRs coupled with CSRR etched on the ground plane shows that there are two transmission zeros i.e., two bands of rejection on both sides of the passband which are: 4.1 GHz and 6.8 GHz at -36dB and -45dB respectively also the refractive index is found to be negative around these two frequencies.

2) for a microstrip transmission line loaded with single Omega SRR coupled with CSRR etched on the ground plane shows that there are two transmission zeros i.e., two bands of rejection on both sides of the passband which are: 4 GHz and 6.9 GHz at -27dB and -29.5dB respectively also the refractive index is found to be negative around these two frequencies.

3) for a simple microstrip transmission line, the return

loss S11 is found to be 0 dB which indicates that there is no transmission band.

## 9. CONCLUSION

The theory of transmission lines, microstrip lines, the SRRs and the CSRRs, the dual-band rejection with reflection characteristics, as well as the approach of NRW are introduced in this work. The band-stop filter is based on a novel concept; the performance and compact size are achieved through the loading of the transmission line by SRRs and CSRRs. The filter adapts better to reduce interference in wireless communication systems due to the simplicity of design, compact size and high selectivity.

### Conflict of interest statement

Authors declare that they do not have any conflict of interest.

## REFERENCES

- [1] GTheory and Application of Left-Handed Metamaterials by Joe Pacheco, Jr. February 2004 Massachusetts Institute of Technology 2004. All rights reserved.
- [2] On the use of Split Ring Resonator and complimentary Split Ring Resonator for novel printed microwave elements, simulations, experiments and discussions by Volkan Öznazlı and Vakur B. Ertürk, Bilkent University
- [3] Determination of effective permittivity and permeability of metamaterials from reflection and transmission coefficients by D. R. Smith\* and S. Schultz, Department of Physics, University of California.
- [4] A. Sihvola. Metamaterials in electromagnetic. Metamaterials, vol. 1, no. 1, February 2007.
- [5] High Frequency Structure Simulator, (HFSS v13), Ansoft corp.
- [6] Antenna Theory, 3rd edition, Constantine A Balanis