

# An Efficient Approach for Designing and Minimizing Reversible Programmable Logic Arrays

Anjaneyulu A<sup>1</sup> | K.Amruthavally<sup>2</sup>

<sup>1,2</sup>Department of Electronics and Communication Engineering, V.R.S & Y.N.R. College of Engineering and Technology, Chirala, Andhra Pradesh, India.

## To Cite this Article

Anjaneyulu A and K.Amruthavally, "An Efficient Approach for Designing and Minimizing Reversible Programmable Logic Arrays", *International Journal for Modern Trends in Science and Technology*, Vol. 04, Issue 04, April 2018, pp.-78-82.

## ABSTRACT

In modern technologies, power dissipation is an important issue and overheating is a serious concern for both manufacturer and consumer. Reversible computing dissipates zero energy in terms of information loss. The development in the field of nanometer technology leads to minimize the power consumption of logic circuits. Reversible logic design has been one of the promising technologies gaining greater interest due to less dissipation of heat and low power consumption. On the other hand, configurability of PLDs (Programmable Logic Devices) reduces NRE (Non-recurring engineering) cost and makes faster design process that offers customer a wide range of logic capacity, features, speed and voltage characteristics. In this paper, we propose a design methodology of RPLA (Reversible Programmable Logic Array) which reduces number of reversible gates, garbage outputs, quantum cost and constant inputs. An algorithm has been proposed for the construction of AND Plane and OR Plane of the RPLA. Comparative results show that the proposed design outperforms the existing designs in terms of numbers of gates, garbage outputs, quantum cost and constant inputs.

**Keywords:** Reversible logic; PLA; Decoder gate; NMGate; AND Plane; ORPlane.

Copyright © 2018 International Journal for Modern Trends in Science and Technology  
All rights reserved.

## I. INTRODUCTION

Reversible computing dissipates zero energy in terms of information loss [1]. In the past, few decades, reversible logic has become one of the most promising research areas. In modern technologies, power dissipation is an important issue and overheating is a serious concern for both manufacturer and consumer. Whereas, in irreversible world, for each bit of information,  $kT \ln 2$  joules of energy is dissipated, where  $k$  is Boltzmann constant and  $T$  is absolute temperature [2].

Variety of PLD (Programmable Logic Device), PLA (Programmable Logic Array) and PAL

(Programmable Array Logic) was introduced by Fleisher and Maissel [3]. In [4] authors show the design of Reversible PLA (RPLA) with Fredkin and Feynman gates whereas, authors in [5] used Mux gate. Both designs are nonprogrammable and non cascade able. In addition, in [6] a cascade able and programmable design is proposed. These designs are not compact and efficient in terms of the performance comparison parameters.

Five main contributions are addressed in this paper:

- 1) We propose the AND plane of RPLA which is compact in terms all cost parameters of reversible logic.
- 2) A new gate, namely New Mux Gate, is proposed to design low cost OR plane of RPLA.
- 3) An Algorithm is proposed to construct the RPLA.

- 4) Two theorems prove the exactness of the design.
- 5) Comparative results demonstrate the supremacy of the design methodology.

The organization of this paper is as follows: In the next Section, basic definitions and properties of Reversible Logic and Programmable Logic Array are given. In Section III, we describe the earlier approaches of RPLA design and their limitations. In Section IV, we propose an algorithm to construct the RPLA. In Section V, we show the performance analysis of the proposed circuit. In Section VI, we show the synthesis and simulations of the proposed circuit. Finally, the paper is concluded with Section VII.

## II. LITERATURE SURVEY

### A. Reversible Logic Gates

Definition 1: A Reversible Circuit is a circuit in which the number of inputs and the number of outputs are equal. There is one-to-one mapping between input and output vectors, i.e.  $IV \leftrightarrow OV$ , where input vector  $IV = (I_1, I_2, \dots, I_{k-1}, I_k)$  and output vector  $OV = (O_1, O_2, \dots, O_{k-1}, O_k)$ .

Definition 2: Every gate's output, that is not used as input to other gates or as a primary output is known as Garbage.

Definition 3: Every quantum circuit is built from  $1 \times 1$  and  $2 \times 2$  quantum primitives and its cost is calculated as a total sum of  $2 \times 2$  gates used since  $1 \times 1$  gate costs nothing i.e. zero. Basically the quantum primitives are matrix operation which is applied on qubits state. All the gates of the form  $2 \times 2$  has equal Quantum cost and the cost is unity i.e. 1.

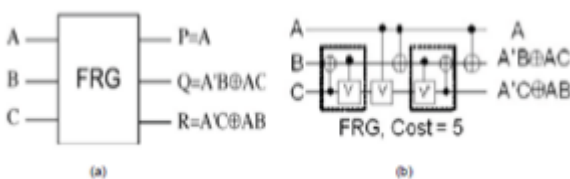

Fig. 1. Fredkin Gate : (a) Block diagram (b) Quantum circuit

The quantum cost of Fredkin gate [7] is 5, whereas, the quantum cost of HL gate [8] is 7. Block diagrams and quantum circuits of Fredkin gate and HL gate are given in Fig.1 and Fig.2, respectively.

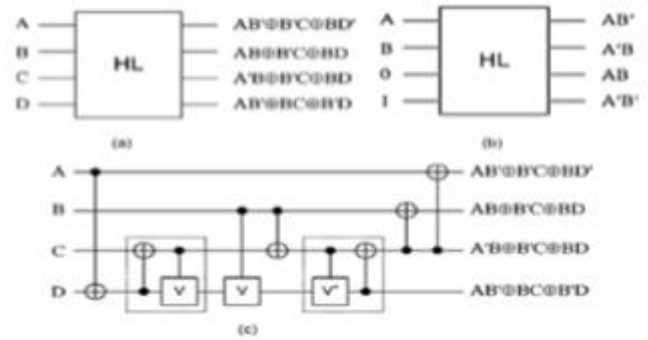

Fig. 2. a) HL Gate (b) HL Gate as Decoder (c) Quantum circuit

Definition 4: Programmable Array Logic Array (PLA) consists of two planes, the first one is programmable AND plane and the second one is programmable OR plane which is all together known as AND-OR PLA [9]. Fig. 3 shows a PLA.

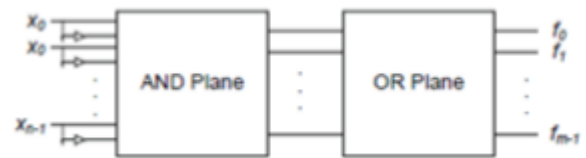

Fig. 3. Block Diagram of Programmable Logic Array

### B. Design Analysis of Existing Techniques

In this section, we discuss about different types of existing RPLA [4], [5], [6]. A 3-input RPLA circuit using Feynman and Fredkin (FRG) gate is designed in [4]. Total 16 FRG gates are used to generate minterms of 3 variables, letting first two outputs of all FRG gates as don't care outputs which cause huge garbage outputs. This design is not programmable. That is, the designers cannot program its array to generate any desirable function. Authors in [5] showed a cost effective method to design the RPLA with MUX gate instead of FRG gate. It also has problem in scalability and dynamism. Authors in [6] proposed 4 different architectures of AND plane. All the existing designs require huge constant inputs and gate, produce extra garbage outputs and have high quantum cost. In this paper, we propose a compact and low cost architecture of RPLA circuit.

## III. PROPOSED DESIGN OF REVERSIBLE PLA

It consists of two planes: AND plane and OR plane. Product terms are generated by AND plane and feed to OR plane. In OR plane, combination of some product terms are evaluated according to user's required functions. In this section, we describe the design procedure of the RPLA.

A. Proposed Reversible Gate

We propose a 3×3 reversible gate, namely New Mux Gate (NMG), which uniquely maps between input vector  $I_v = (I_0, I_1, I_2)$  and output vector  $O_v = (O_0, O_1, O_2)$ , where,  $O_0 = A \oplus B$ ,  $O_1 = BCr \oplus AC$  and  $O_2 = BrC \oplus ACr$ . Truth table of the NMG gate is given to prove its reversibility in Table I, whereas Fig.4(a), Fig.4(b) and Fig.4(c) show the block diagram, the implementation of the NMG gate as OR and AND functions and quantum circuit of NMG gate, respectively.

TABLE1:TRUTH TABLE OF NMG GATE

A	B	C	P	Q	R
0	0	0	0	0	0
0	0	1	0	0	1
0	1	0	1	1	0
0	1	1	1	0	0
1	0	0	1	0	1
1	0	1	1	1	1
1	1	0	0	1	1
1	1	1	0	1	0

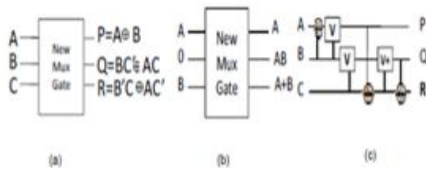

Fig.4. NMG Gate:(a) Block diagram (b) ANDOR implementation (c) Quantum circuit

B. Design of AND Plane of RPLA

In the AND plane, minterms are generated by the logic gates. To design the general architecture for n variables, at first 2-variable minterms are generated. In our proposed design, we use 2-to-4 decoder HL gate proposed in [8]. As, this gate can implement four minterms of two variables and does not require any extra circuit to copy the inputs and to produce outputs, the design of AND plane is compact, cost effective and garbage free for two input variables. Fig. 2(b) shows the implementation of four minterms by HL gate. Fig. 5 shows that a 3-to-8 decoder can be constructed with four FRG gates and one HL gate which will produce eight minterms of three variables for AND plane. This design is scalable and hence reversible AND array of n variables can be designed with (n - 1)-to-2(n-1)decoder and 2(n-1)FRG gates.

C. Design of OR Plane of RPLA

In this section, we propose the design of programmable OR array circuit. The main inputs to this circuit are eight minterms,  $m_i$  for  $i = 0$  to 7),

and eight selector lines,  $s_i$  for  $i = 0$  to 7. The detailed design of this programmable OR array is shown in Fig. 5. NMG gates are used to perform the AND and OR operations. NMG gates of the first column of the design produce the copy of the minterms plus the AND terms of  $m_i.s_i$ 's, for  $i = 0$  to 7. NMG gates of the second column of the design produce the OR of two terms of  $m_i.s_i + m_{i+1}.s_{i+1}$ 's, for  $i = 0, 2, 4, 6$ . NMG gates of the third column produce the OR of four terms of  $m_i.s_i$ 's. And finally, the NMG gate of the last column produces the main output O of the OR array which is the OR of all  $m_i.s_i$ 's, for  $i = 0$  to 7. The main output of this OR array, O, can be programmed through the selector lines,  $s_i$ , to produce any desired boolean function. The selector lines can be changed to set or reset to select the appropriate minterms of a function. The proposed design of the OR array also produces a copy of the minterms at its outputs. These minterms can be used in another OR array to produce another Boolean function, without need to use another AND array. That means the proposed reversible and programmable OR array is also cascadeable circuit.

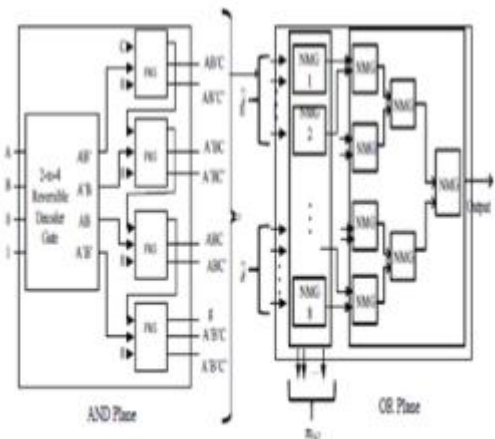

Fig. 5. Proposed AND array and OR array for 3variable single output function

Algorithm 1 describes the construction of the RPLA circuit.

**Algorithm 1:** Algorithm to construct the reversible PLA

**Input:** Any Benchmark Functions

**Output:** Realization of reversible PLA circuit  
1 begin

2 Construct n bit decoder with HL gate, that will act like the AND Plane of RPLA and will generate all the minterms of n variables.

3 Use 2n-1 NMG gate of which the inputs are 2k minterms and 2k selection bits, the outputs are copies of 2k minterms along with selected terms those will be fed to NMG OR gates.

4 Use  $2n-1$  NMG gates to get the resulting OR plane.

5 end

Theorem 4.1: Let,  $n$  be the number of input variables of AND plane of RPLA. The number of gates to realize AND plane of RPLA is at least  $2n-3$  for  $n \geq 2$ . Proof: We prove the above statement by induction. For  $n = 2$ , required number of gate is  $2 \cdot 2 - 3 = 1$ . So, the statements holds for the base case  $n = 2$ . Assume that, the statement holds for  $n = k$ . So, the  $k$ -input AND plane requires  $2k-3$  gates.  $k+1$ -input AND plane is constructed using  $k$ -input AND plane ( $k$ -to- $2k$  decoder) and  $2k$  Fredkin gates. So, total number of gate required for  $n=k+1$  AND plane is  $2k-3+2k=2k+13$ . So, the statement holds for  $n = k+1$ . Therefore,  $n$ -input AND array requires at least  $2n-3$  gates, where  $n \geq 2$ .

Theorem 4.2: Let,  $n$  be the number of input variables of AND plane of RPLA. Number of garbage output to realize AND plane of RPLA is at least  $n-2$ , where  $n \geq 2$ . Proof: We prove the above statement by induction. The AND plane produces minterms by using decoders.

A 2-to-4 ( $n = 2$ ) decoder requires only one HL gate. All of the outputs of the HL gates are used to design a 2-to-4 decoder. So, no garbage output is produced by the HL gate (shown in Fig.2 (b)). So, a 2-input AND array generates at least  $0 (=2-2)$  garbage output. The statement holds for the base case  $n = 2$ .

Assume that, the statement holds for  $n = k$ . So, a  $k$ -to- $2k$  decoder generates at least  $k-2$  garbage outputs. A  $(k+1)$ -to- $2k+1$  decoder is constructed using  $k$ -to- $2k$  decoder and  $2k$  Fredkin gates. A  $k$ -to- $2k$  decoder generates at least  $k-2$  garbage outputs and only the last FRG gate produces one garbage output.

So, total number of garbage outputs generated by a  $(k+1)$ -to- $2k+1$  decoder is at least  $k-2+1=(k+1)-2$ . So, the statement holds for  $n=k+1$ . Therefore,  $n$ -input AND array produce at least  $n-2$  garbage outputs, where  $n \geq 2$ .

*D. Programming of the proposed RPLA to design 3-input multi-output function*

Proposed RPLA can implement any Boolean function. For example, one of the benchmark circuits for three inputs inc3.pla is selected to construct the RPLA. The circuit diagram of implementing the inc3.pla is given in Fig. 6.

**IV. PERFORMANCE ANALYSIS**

In this Section, we analyze the performance of our proposed design with existing designs [4], [5], [6]. Table II and Table III show the comparative results of our proposed method and existing methods presented in [4], [5], [6] in terms of number of gates, garbage outputs, quantum cost and constant input for 3 input RPLA and  $n$ -input RPLA, respectively. These tables indicate the compactness and cost efficiency of the proposed design. From Fig. 6, it is clear that the circuit of any benchmark function can be constructed by following the proposed methodology.

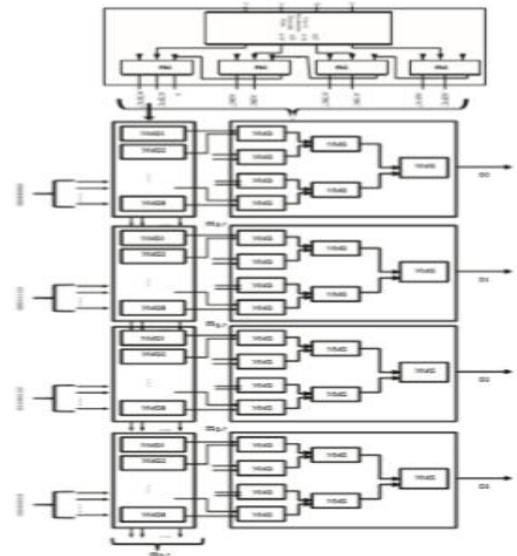

Fig. 6. Implementing inc3.pla by using the proposed reversible PLA architecture.

**V. SIMULATION RESULTS**

All the synthesis and simulation results of the Proposed Reversible 3-Variable PLAs are performed using Verilog HDL. The synthesis and simulation are performed on Xilinx ISE 14.4. The corresponding simulation results of Proposed Reversible 3-Variable PLAs are shown below.

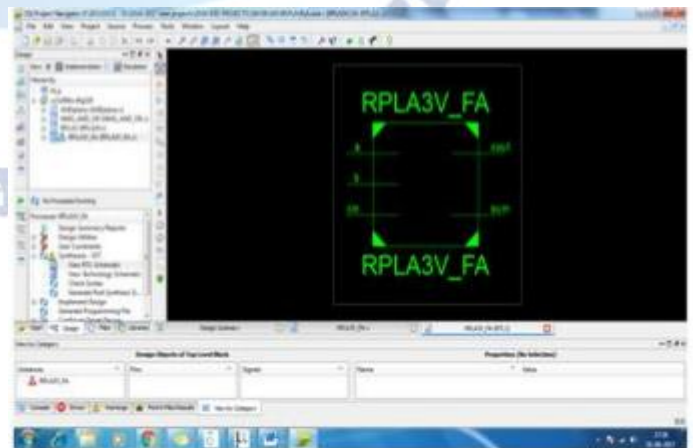

Figure 13: RTL schematic of Top-level of Proposed Reversible 3-Variable PLA

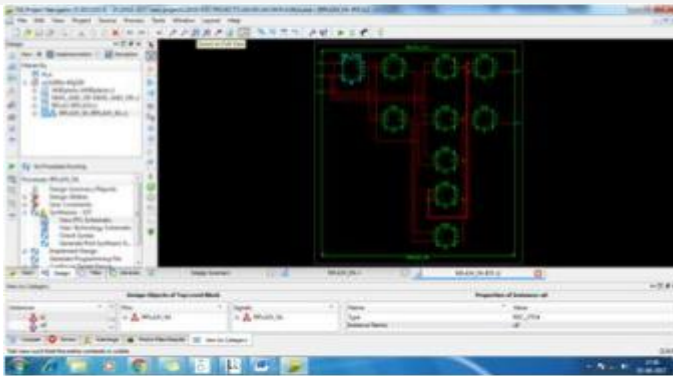

Figure 14: RTL schematic of Internal block of Proposed Reversible 3-Variable PLA

## VI. CONCLUSION

This paper presented the design methodology of an efficient and generalized reversible Programmable Logic Array (RPLA). The proposed a compact structure for Reversible Programmable Logic Array (RPLA) which is programmable and scalable for  $n$  variables. The proposed decoder circuit serves as the AND Array whereas, tree structure of NMG gates constructs the OR Array. The Proposed algorithm focuses on the construction of the RPLA, which can realize any multi-output Sum of Product function. Besides, a circuit is constructed for a multi-output benchmark PLA as an example. Furthermore, we proved the efficiency and explained the characteristics of the proposed architecture with several theorems and explanations. Comparative analysis shows that the proposed design methodology requires less number of gates, produces less garbage outputs and reduces quantum cost.

## REFERENCES

- [1] C.H. Bennett, "Logical reversibility of computation". IBM J. Res. Dev., vol.17, no. 6, pp. 525-532, 1973.
- [2] R. Landauer, "Irreversibility and heat generation in the computing process." IBM J. Res. Dev., vol.5, no. 3, pp. 183-191, 1961.
- [3] H. Fleisher and L. I. Maissel, "An introduction to array logic", IBM Journal of Research and Development, vol. 19, 1975.
- [4] H. Thapliyal and H. R. Arabnia, "Reversible Programmable Logic Array (RPLA) using Fredkin and Feynman gates for industrial electronics and applications", Proc. Int. Conf. Embedded Systems and Applications (ESA'06), Las Vegas, USA, June 2006.
- [5] Pradeep Singla and Naveen Kr. Malik, "A cost effective design of Reversible Programmable Logic Array", International Journal of Computer Applications, vol. 41,2012.

- [6] MashidTayari and Mohammad Eshghi, "Design of 3-input reversible programmable logic array", Journal of Circuits, Systems and Computers, vol. 20, No.2, pp 283-297,2011.
- [7] E. Fredkin, E. Toffoli, "Conservative logic", International Journal of Theoretical Physics 21 (1983) 219253.
- [8] Lafifa Jamal, Md. MasbaulAlam and Hafiz Md. HasanBabu, "An efficient approach to design a reversible control unit of a processor", Journal of Sustainable Computing: Informatics and Systems, ), vol. 3, pp 286-294, 2013.
- [9] RubaiyaRahman, Lafifa Jamal and Hafiz Md. HasanBabu, "Design of reversible fault tolerant programmable logic arrays with vector orientation", International Journal of Information and Communication Technology Research, vol. 1, no. 8, pp 337-343, 2011.
- [10] G. Schrom and S. Selberherr. Ultra-low-power cmos technology. In Semiconductor Conf., Romania, 2002. E. Knill, R. Laamme, and G. J. Milburn. A scheme for efficient quantum computation with linear optics. Nature, 409:46-52, January 2001.