



IOT-Enabled Remote-Controlled Smart Power Outlet and Load Management System Using Arduino UNO

T. Harinadh, U. Venkata Sunil, N. Divyesh, R. Sai Krishna, P. Guru Chandu

Department of CSE – Data Science, Chalapathi Institute of Technology, Guntur-522016, A.P, India

To Cite this Article

T. Harinadh, U. Venkata Sunil, N. Divyesh, R. Sai Krishna & P. Guru Chandu (2026). IOT-Enabled Remote-Controlled Smart Power Outlet and Load Management System Using Arduino UNO. International Journal for Modern Trends in Science and Technology, 12(SI01), 1231-1237. <https://doi.org/10.5281/zenodo.19769965>

Article Info

Received: 12 March 2026; Revised: 07 April 2026; Accepted: 10 April 2026.

Copyright © The Authors ; This is an open access article distributed under the [Creative Commons Attribution License](#), which permits unrestricted use, distribution, and reproduction in any medium, provided the original work is properly cited.

KEYWORDS

Electric Vehicles (EV), Battery Management System (BMS), Arduino Uno, State of Charge (SoC).

ABSTRACT

The increasing demand for electric vehicles has created a strong need for efficient and reliable battery management systems to ensure safety, performance, and longevity of batteries. This paper presents the design and implementation of an Electric Vehicle Battery Management System (BMS) using an Arduino Uno as the main controller. The system focuses on continuous monitoring of essential battery parameters such as voltage, current, and temperature. Sensors are used to collect real-time data, which is processed by the microcontroller to maintain the battery within safe operating limits. The system is capable of preventing critical conditions such as overcharging, deep discharge, and overheating, thereby reducing the risk of battery damage and improving overall efficiency. A Liquid Crystal Display (LCD) is incorporated to provide real-time feedback to the user, while LEDs are used as indicators for different operational states and warning conditions. Additionally, the system includes basic motor control functionality based on battery status, ensuring efficient energy utilization. The proposed design offers a cost-effective and practical solution for battery monitoring in electric vehicles. Overall, the implementation enhances battery safety, extends lifespan, and contributes to the reliable operation of electric vehicle systems.

I. INTRODUCTION

In recent years, the rapid growth of electric vehicles (EVs) has significantly transformed the transportation sector, driven by the need for sustainable and environmentally friendly solutions. Unlike conventional vehicles that rely on fossil fuels, electric vehicles depend entirely on battery systems for energy storage and power delivery. As a result, the performance, safety, and

reliability of an EV are highly dependent on the effective management of its battery system.

Batteries used in electric vehicles are sensitive to operating conditions such as voltage fluctuations, excessive current, and temperature variations. Improper handling of these parameters can lead to reduced efficiency, shortened battery lifespan, or even hazardous situations like overheating and thermal runaway.

Therefore, a Battery Management System (BMS) plays a crucial role in ensuring that the battery operates within safe and optimal limits.

A BMS is an electronic control system that continuously monitors battery parameters, protects the battery from abnormal conditions, and improves overall performance. It helps in preventing overcharging, deep discharging, and overheating, which are common causes of battery degradation. In addition, modern BMS designs focus on improving energy efficiency and reliability through real-time monitoring and intelligent control techniques [1][2].

In this project, a simple and cost-effective Battery Management System is developed using an Arduino Uno microcontroller. The system integrates various sensors to measure voltage, current, and temperature, and processes the data to ensure safe battery operation. A display unit is used to provide real-time information to the user, while LEDs indicate system status and warning conditions. The system also includes basic control over motor operation based on battery conditions, enhancing energy utilization.

The primary objective of this work is to design a reliable and efficient battery monitoring system that can improve safety, extend battery life, and ensure better performance in electric vehicles. This approach provides a practical solution suitable for small-scale EV applications and educational purposes, while also serving as a foundation for further advancements in battery management technologies [3][4].

2. REVIEW LITERATURE SURVEY

The development of efficient Battery Management Systems (BMS) has been an important area of research due to the increasing adoption of electric vehicles. Various researchers have contributed to improving battery performance, safety, and monitoring techniques through different approaches.

A study by H. He, R. Xiong, and J. Fan focused on the fundamental role of BMS in electric vehicles, highlighting the importance of monitoring critical parameters such as voltage, current, and temperature. The authors emphasized the need for accurate estimation of State of Charge (SOC) and State of Health (SOH) to ensure reliable battery performance and extended lifespan [1]. Their work established a strong

foundation for understanding the core functionalities required in a BMS.

Similarly, S. Li and B. Ke presented a comprehensive review of battery management techniques, discussing various protection mechanisms and control strategies. Their research addressed challenges such as thermal management and cell balancing, which are essential for maintaining battery stability. The study concluded that an effective BMS not only enhances battery efficiency but also reduces the chances of system failure [2].

Further advancements in BMS technologies were explored by M. A. Hannan, M. M. Hoque, and A. Mohamed, who introduced advanced monitoring and control methods. Their work highlighted the use of intelligent algorithms and fault detection techniques to improve system reliability. The authors demonstrated that modern BMS solutions are increasingly incorporating automation and smart control features to handle complex battery behaviors [3].

In addition, P. Verma and A. Kumar proposed an IoT-based battery monitoring system that enables real-time data tracking and remote monitoring. Their approach allows users to access battery status through cloud-based platforms, improving maintenance and early fault detection. This study shows how connectivity and digital technologies can enhance the efficiency of battery management systems [4].

Moreover, recent research by Y. Zhang and C. Wang explored the integration of Artificial Intelligence (AI) in BMS design. The authors demonstrated how machine learning algorithms can be used to predict battery performance, estimate SOC and SOH more accurately, and detect faults at an early stage. Their findings indicate that AI-based systems significantly improve battery safety, efficiency, and lifespan compared to traditional methods [5].

From the above studies, it is evident that Battery Management Systems have evolved from basic monitoring units to advanced intelligent systems. However, many of these solutions involve high complexity and cost. Therefore, there is a need for a simple, cost-effective, and reliable BMS design, which motivates the development of the proposed Arduino-based system in this project.

3. RESEARCH METHODOLOGY

The methodology adopted in this project focuses on the design and implementation of a simple, cost-effective Battery Management System (BMS) for electric vehicles using an Arduino Uno microcontroller. The approach involves systematic integration of hardware components, sensor-based data acquisition, and real-time monitoring to ensure safe battery operation.

A. System Design Approach

The proposed system is designed to continuously monitor key battery parameters such as voltage, current, and temperature. These parameters are critical in determining the health and performance of the battery. Sensors are used to capture real-time data, which is then processed by the Arduino Uno. Based on the processed information, the system takes necessary actions to maintain safe operating conditions.

The design follows a modular approach, where each component performs a specific function. This includes sensing units, processing unit, display system, and control mechanisms. Such a structured design improves system reliability and makes it easier to implement and troubleshoot.

B. Hardware Implementation

The hardware setup consists of an Arduino Uno as the central controller, along with voltage sensors, current sensors, and temperature sensors. These sensors are connected to the analog input pins of the microcontroller, allowing continuous data acquisition.

A Liquid Crystal Display (LCD) is used to display real-time battery information such as voltage levels and system status. LEDs are included to indicate different operating conditions, such as normal operation, warning, or fault states. A motor driver circuit is also integrated to control motor operation based on battery conditions.

The system is powered using a regulated power supply to ensure stable voltage for all components. Proper interfacing between components ensures accurate data collection and reliable system performance.

C. Software Implementation

The software for the system is developed using the Arduino Integrated Development Environment (IDE). The program is written in embedded C/C++ and consists of two main functions: `setup()` and `loop()`.

In the `setup()` function, all input and output devices are initialized, including sensors, LCD, and LEDs. The `loop()`

function continuously reads sensor data, processes it, and updates the display and indicators accordingly.

The algorithm is designed to compare sensor readings with predefined threshold values. If any parameter exceeds safe limits, the system triggers warning signals or takes control actions such as stopping the motor to prevent damage.

D. Data Monitoring and Control Strategy

The system continuously monitors battery parameters in real-time. The collected data is analyzed to detect abnormal conditions such as overvoltage, undervoltage, or excessive temperature. Based on this analysis, appropriate actions are taken to protect the battery.

This real-time monitoring approach improves battery safety and helps in early fault detection. It also ensures efficient energy utilization by controlling the motor based on battery status.

E. System Validation

The proposed system is tested under different operating conditions to verify its performance. The sensor readings are observed through the LCD display, and system responses are checked for various scenarios such as high temperature or low voltage.

The results confirm that the system effectively monitors battery parameters and responds appropriately to abnormal conditions, thereby improving safety and reliability.

4. PROPOSED METHODOLOGY

The proposed system aims to develop a simple and cost-effective Battery Management System (BMS) using an Arduino Uno microcontroller to ensure safe and efficient operation of electric vehicle batteries. The system is designed to continuously monitor important battery parameters such as voltage, current, and temperature. These parameters are measured using appropriate sensors and are essential for determining the overall health and performance of the battery.

The working of the system is based on real-time data acquisition and processing. The sensors collect battery data and send it to the Arduino Uno, which acts as the central processing unit. The microcontroller analyzes the received data by comparing it with predefined safe limits. If the parameters remain within the safe range, the system continues to operate normally. However, if any parameter exceeds its threshold value, the system

immediately detects the abnormal condition and initiates necessary protective actions.

To enhance safety, the system includes a control mechanism that prevents damage to the battery. When conditions such as overvoltage, undervoltage, or excessive temperature are detected, the Arduino activates warning indicators and can control the motor operation through a motor driver circuit. This helps in avoiding harmful situations like overheating or deep discharge, thereby increasing battery life and ensuring reliable performance.

The system also provides a user-friendly interface through a 16x2 LCD display, which shows real-time battery information such as voltage levels and system status. In addition, LED indicators are used to represent different operating conditions, allowing the user to quickly understand whether the system is functioning normally or if there is a fault.

Overall, the proposed methodology focuses on continuous monitoring, timely decision-making, and protective control actions. This approach not only improves battery safety and efficiency but also offers a practical and low-cost solution suitable for small-scale electric vehicle applications and educational purposes.

WORKING PRINCIPLE

The working principle of the proposed Battery Management System (BMS) is based on continuous monitoring, processing, and control of key battery parameters to ensure safe and efficient operation. The system uses sensors to measure important parameters such as voltage, current, and temperature of the battery in real time. These sensors are connected to the Arduino Uno microcontroller, which acts as the central processing unit of the system.

As the battery operates, the sensors continuously collect data and send it to the Arduino. The microcontroller reads these values through its analog input pins and processes them using programmed logic. The measured values are then compared with predefined threshold limits to determine whether the battery is operating under safe conditions. If all parameters are within the acceptable range, the system continues normal operation without any interruption.

However, if any abnormal condition is detected, such as overvoltage, excessive current, or high temperature, the

system immediately responds by activating warning indicators like LEDs and displaying alert messages on the LCD screen. In critical situations, the system can also control or stop the motor operation through a motor driver circuit to prevent further damage to the battery.

The LCD display provides real-time information about the battery status, allowing the user to monitor system performance continuously. LED indicators offer quick visual feedback for different operating conditions. This combination of monitoring, decision-making, and control ensures that the battery operates within safe limits, thereby improving its lifespan, efficiency, and overall reliability.

BLOCK DIAGRAM

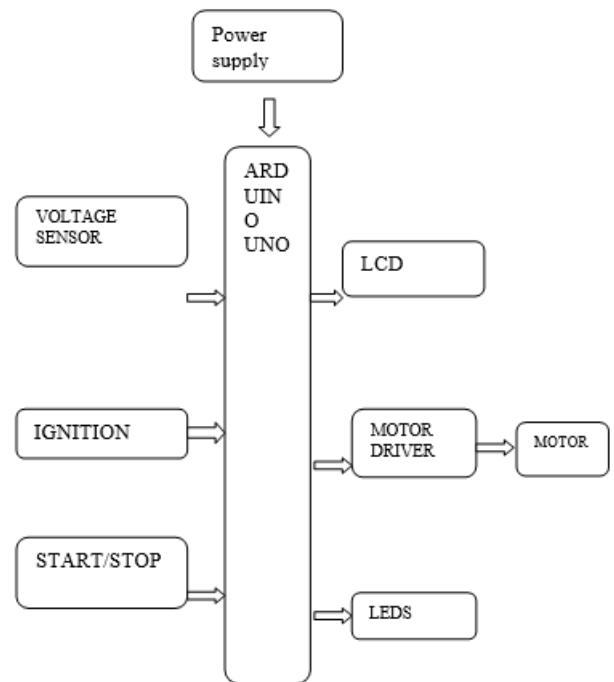

Fig 4.1: Block Diagram

5. RESULTS AND OUTCOMES

The implemented Battery Management System (BMS) was successfully tested under different operating conditions to evaluate its performance and reliability. The system was able to continuously monitor key battery parameters such as voltage, current, and temperature in real time. The sensor readings were accurately displayed on the LCD, allowing easy observation of battery status during operation.

During testing, the system effectively detected abnormal conditions such as overvoltage, undervoltage, and

increased temperature. Whenever these conditions occurred, the system responded immediately by activating LED indicators and displaying warning messages on the LCD. This confirmed that the system is capable of providing timely alerts and ensuring battery safety.

The control mechanism of the system also functioned as expected. When unsafe conditions were detected, the Arduino successfully controlled the motor operation through the motor driver circuit, preventing further damage to the battery. This demonstrated the system's ability to take protective actions automatically without user intervention.

The overall performance of the system showed that it is reliable, efficient, and suitable for real-time battery monitoring applications. The use of Arduino Uno made the system simple and cost-effective while still maintaining good accuracy and responsiveness. The integration of sensors, display unit, and control features worked smoothly, resulting in a stable and functional BMS.

In conclusion, the developed system achieved its objective of improving battery safety, enhancing performance, and extending battery life. The results indicate that this approach can be effectively used in small-scale electric vehicle applications and can serve as a foundation for further improvements and advanced battery management solutions.

6. CONCLUSION

The development of an efficient Battery Management System (BMS) is essential for ensuring the safe and reliable operation of electric vehicles. In this project, a simple and cost-effective BMS has been successfully designed and implemented using an Arduino Uno microcontroller. The system effectively monitors key battery parameters such as voltage, current, and temperature in real time, which are critical for maintaining battery health and performance.

The proposed system demonstrated its ability to detect abnormal conditions such as overcharging, deep discharge, and overheating. By providing timely warnings through LEDs and LCD display, and by controlling motor operation during unsafe conditions, the system enhances battery safety and prevents potential damage. This not only improves the overall

efficiency of the system but also contributes to extending the battery lifespan.

Compared to complex and expensive battery management solutions, the developed system offers a practical and economical alternative, especially suitable for small-scale electric vehicle applications and educational purposes. The results confirm that continuous monitoring and timely control actions play a significant role in improving battery reliability and performance [1][2].

In conclusion, the project successfully meets its objectives by providing a reliable, user-friendly, and efficient battery monitoring system. It also serves as a strong foundation for future enhancements, such as integrating advanced technologies like IoT and artificial intelligence for smarter and more autonomous battery management systems [3][4][5].

Conflict of interest statement

Authors declare that they do not have any conflict of interest.

REFERENCES

- [1] K. K. Kommineni and A. Prasad, "A Review on Privacy and Security Improvement Mechanisms in MANETs", *Int J Intell Syst Appl Eng*, vol. 12, no. 2, pp. 90–99, Dec. 2023.
- [2] Kommineni, K.K., Prasad, A. Enhancing Data Security and Privacy in SDN-Enabled MANETs Through Improved Data Aggregation Protection and Secrecy. *Wireless Pers Commun* 139, 855–882 (2024). <https://doi.org/10.1007/s11277-024-11635-w>
- [3] "Blockchain-Enabled Secure Data Aggregation for SDN-Enabled Ad-Hoc Networks," *International Journal of Intelligent Engineering and Systems*, vol. 18, no. 5, pp. 704–717, Jun. 2025, doi: <https://doi.org/10.22266/ijies2025.0630.49>.
- [4] K. K. Kommineni, P. Ande, "Blockchain-driven key management and privacy-preserving data Aggregation Scheme for SDN-enabled MANETs," *International Journal of Intelligent Engineering and Systems*, vol. 18–18, no. 9, pp. 601–615, 2025, doi: [10.22266/ijies2025.1031.39](https://doi.org/10.22266/ijies2025.1031.39).
- [5] Kumar, K. K., Kumar, S. G. B., Rao, S. G. R., & Sydulu, S. S. J. (2017, November). Safe and high secured ranked keyword searchover an outsourced cloud data. In 2017 International Conference on Inventive Computing and Informatics (ICICI) (pp. 20-25). IEEE.
- [6] K. K. Kommineni, S. J. Basha, M. Sandeep, P. S. Vadana, T. S. R. Sai and D. S. Kumar, "A Review on IoT-based Defensive Devices for Women Security," 2023 9th International Conference on Advanced Computing and Communication Systems (ICACCS), Coimbatore, India, 2023, pp. 99-104, doi: [10.1109/ICACCS57279.2023.10113015](https://doi.org/10.1109/ICACCS57279.2023.10113015).
- [7] Vellela, S. S., & Balamaniandan, R. (2024). Optimized clustering routing framework to maintain the optimal energy status in the wsn mobile cloud environment. *Multimedia Tools and Applications*, 83(3), 7919-7938.
- [8] Vellela, S. S., & Balamaniandan, R. (2023). An intelligent sleep-awake energy management system for wireless sensor

- network. *Peer-to-Peer Networking and Applications*, 16(6), 2714-2731.
- [9] Vellela, S. S., & Balamanigandan, R. (2022, December). Design of Hybrid Authentication Protocol for High Secure Applications in Cloud Environments. In *2022 International Conference on Automation, Computing and Renewable Systems (ICACRS)* (pp. 408-414). IEEE.
- [10] Vellela, S. S., Balamanigandan, R., & Praveen, S. P. (2022). Strategic survey on security and privacy methods of cloud computing environment. *Journal of Next Generation Technology*, 2(1).
- [11] Reddy, N. V. R. S., Chitteti, C., Yesupadam, S., Desanamukula, V. S., Vellela, S. S., & Bommagani, N. J. (2023). Enhanced Speckle Noise Reduction in Breast Cancer Ultrasound Imagery Using a Hybrid Deep Learning Model. *Ingenierie des Systemes d'Information*, 28(4), 1063.
- [12] Vellela, S. S., & Balamanigandan, R. (2024). An efficient attack detection and prevention approach for secure WSN mobile cloud environment. *Soft Computing*, 28(19), 11279-11293.
- [13] Polasi, P. K., Vellela, S. S., Narayana, J. L., Simon, J., Kapileswar, N., Prabu, R. T., & Rashed, A. N. Z. (2026). Data rates transmission, operation performance speed and figure of merit signature for various quadrature light sources under spectral and thermal effects. *Journal of Optics*, 55(1), 633-643.
- [14] Vellela, S. S., & Krishna, A. M. (2020). On Board Artificial Intelligence With Service Aggregation for Edge Computing in Industrial Applications. *Journal of Critical Reviews*, 7(07).
- [15] Vellela, S. S., Rao, M. V., Mantena, S. V., Reddy, M. J., Vatambeti, R., & Rahman, S. Z. (2024). Evaluation of Tennis Teaching Effect Using Optimized DL Model with Cloud Computing System. *International Journal of Modern Education and Computer Science (IJMECS)*, 16(2), 16-28.
- [16] Biyyapu, N., Veerapaneni, E. J., Surapaneni, P. P., Vellela, S. S., & Vatambeti, R. (2024). Designing a modified feature aggregation model with hybrid sampling techniques for network intrusion detection. *Cluster Computing*, 27(5), 5913-5931.
- [17] Vuyyuru, L. R., Purimetla, N. R., Reddy, K. Y., Vellela, S. S., Basha, S. K., & Vatambeti, R. (2025). Advancing automated street crime detection: a drone-based system integrating CNN models and enhanced feature selection techniques. *International Journal of Machine Learning and Cybernetics*, 16(2), 959-981.
- [18] Praveen, S. P., Vellela, S. S., & Balamanigandan, R. (2024). SmartIris ML: harnessing machine learning for enhanced multi-biometric authentication. *Journal of Next Generation Technology (ISSN: 2583-021X)*, 4(1).
- [19] Vellela, S. S., Roja, D., Purimetla, N. R., Thalakola, S., Vuyyuru, L. R., & Vatambeti, R. (2025). Cyber threat detection in industry 4.0: Leveraging GloVe and self-attention mechanisms in BiLSTM for enhanced intrusion detection. *Computers and Electrical Engineering*, 124, 110368.
- [20] Vellela, S. S., Varshini, K., Jeevana, M., Kadheer, S. K., & Kumar, T. P. (2024). Iot based smart irrigation and controlling system. *IoT Based Smart Irrigation and Controlling System*, *International Journal for Modern Trends in Science and Technology*, 10(02), 77-85.
- [21] Vellela, S. S., Manne, V. K., Trividha, G., Chaithanya, L., & Shaik, A. (2025). Intelligent transportation systems ai and iot for sustainable urban traffic management. Available at SSRN 5250812.
- [22] Vindhya, A. S., Vellela, S. S., Malathi, N., Vullam, N. R., Vuyyuru, L. R., & Rao, T. (2025, September). Integrating Quantum Computing with Genomic Data Analysis: A Next-Generation Approach for Predicting Disease Susceptibility. In *2025 4th International Conference on Innovative Mechanisms for Industry Applications (ICIMIA)* (pp. 1168-1173). IEEE.
- [23] Vellela, S. S., Rao, M. V., Krishna, C. V. M., Rao, T. S., & Dasthajejula, R. (2026). Piezoelectric and Shape-Memory Materials for Actuators and Energy Harvesting in Mechanical, Electronics, and Biomedical Engineering Using AI-Based Design. In *Advanced Materials for Biomedical Devices* (pp. 195-206). CRC Press.
- [24] Vellela, S. S., Malathi, N., Vuyyuru, L. R., Javvadi, S., Rao, T. S., Bindu, M. N. H., & Rao, K. N. (2025, August). Improving Medical Image Analysis with Convolutional Neural Networks (Cnns). In *2025 International Conference on Intelligent and Secure Engineering Solutions (CISES)* (pp. 579-584). IEEE.
- [25] Roja, D., Jidugu, S. K., Rao, T. S., Vuyyuru, L. R., Vellela, S. S., & Ranjani, B. S. (2025, December). High-Fidelity Image Synthesis using Enhanced Generative Adversarial Networks with Attention Mechanisms. In *2025 International Conference on NexGen Networks and Cybernetics (IC2NC)* (pp. 885-890). IEEE.
- [26] Pakalapati, S., Rani, C. J., Vellela, S. S., Thanuja, N., & Bindu, M. N. H. (2025, November). Progressive GAN-based Framework for Realistic Image Generation and Style Transfer. In *2025 5th International Conference on Evolutionary Computing and Mobile Sustainable Networks (ICECMSN)* (pp. 474-479). IEEE.
- [27] Yanamadala, N., & Vellela, S. S. (2025, June). Ensuring Authenticity and Confidentiality in Images using SHA-ECC Fusion. In *2025 Second International Conference on Networks and Soft Computing (ICNSoC)* (pp. 684-689). IEEE.
- [28] Rao, M. V., Sreeraman, Y., Mantena, S. V., Gundu, V., Roja, D., & Vatambeti, R. (2024). Brinjal Crop yield prediction using Shuffled shepherd optimization algorithm based ACNN-OBDLSTM model in Smart Agriculture. *Journal of Integrated Science and Technology*, 12(1), 710-710.
- [29] Reddy, B. V., Kumar, A. H., Gopi, C., Prasad, Y. V. D., Vellela, S. S., & Roja, D. (2025, April). Machine learning based automated liver fibrosis stage diagnosis with prediction. In *2025 International Conference on Advances in Modern Age Technologies for Health and Engineering Science (AMATHE)* (pp. 1-6). IEEE.
- [30] Burra, R. S., APCV, G. R., & Vellela, S. S. (2024). Enhancing Ddos Detection Through Semi-Supervised Machine Learning: A Novel Approach for Improved Network Security. *International Research Journal of Modernization in Engineering Technology and Science*, 6.
- [31] Vellela, S. S., Vullam, N. R., Gorintla, S., Rao, T. S., & Harinadh, T. (2025, July). Exploring the Anti-Inflammatory Potential of Green-Synthesized Pyrazolines. In *2025 6th International Conference on Data Intelligence and Cognitive Informatics (ICDICI)* (pp. 814-819). IEEE.
- [32] Vellela, S. S., Chandra, S. S., Thommandru, R., Mastan Basha, S., & Sri Ram, D. (2023). Novel Approach to Mitigate Starvation in Wireless Mesh Networks. Available at SSRN 5262254.
- [33] Praveen, S. P., Vellela, S. S., Sharma, K., & Dalavai, L. Quantitative Evaluation of Smart Textile Adoption in Rural Weaving Communities using Machine Learning. *Journal of the Textile Association*, 86(3), 277-284.
- [34] Mandava, R., Dalavai, L., Vellela, S. S., Purimetla, N. R., Mohan, B. K., & Harinadh, T. (2025, June). An In-Depth Study on the Integration of Explainable AI Techniques to Enhance Interpretability in Clinical Risk Prediction Models. In *2025 Second International Conference on Networks and Soft Computing (ICNSoC)* (pp. 43-47). IEEE.
- [35] Rao, M. V., Krishna, C. V. M., Vellela, S. S., Vara, J., Paul, K. J., & Rao, K. N. (2025, March). Enhancement and Blind Image Restoration for Quality Improvements of Camera Captured Pictures/Videos. In *2025 7th International Conference on Intelligent Sustainable Systems (ICISS)* (pp. 791-796). IEEE.
- [36] Vellela, S. S., Anusha, P., Vullam, N. R., Jala, J., Bellapu, V. S., & Vindhya, A. S. (2025, October). Quantum Cryptography and Key Distribution for Secure Communication in the Post Quantum World. In *2025 International Conference on Sustainable Communication Networks and Application (ICSCN)* (pp. 619-624). IEEE.

- [37] Vellela, S. S., Vuyyuru, L. R., Jidugu, S. K., Rao, M. P., & Srinivas, B. R. (2025, November). The Impact Of Quantum Computing On Blockchain Security And Quantum Resistant Protocols. In 2025 2nd International Conference on Intelligent Systems for Cybersecurity (ISCS) (pp. 1-6). IEEE.
- [38] Kumar, M. S., Vellela, S. S., Gorintla, S., Malathi, N., Rao, T. S., & Rani, N. R. (2025, October). Intelligent Resource Allocation in Wireless Sensor Networks: A Hybrid Optimization Approach for Energyconstrained Environments. In 2025 2nd International Conference on Electronic Circuits and Signaling Technologies (ICECST) (pp. 724-729). IEEE.
- [39] Krishna, T. V., Rani, N. R., Ranjani, B. S., & Vellela, S. S. (2025). Distributed Big-Data Analytics with PySpark for Personalized Restaurant Recommendation Systems. *Journal of Next Generation Technology* (ISSN: 2583-021X), 5(6).
- [40] Harinadh, T., Anusha, P., Roja, D., Vellela, S. S., & Muthukumar, P. (2025). PySpark Orchestrated Machine Learning Paradigms for Advanced Network Intrusion Detection. *Journal of Next Generation Technology* (ISSN: 2583-021X), 5(6).
- [41] Mandava, R., Haritha, K., Vellela, S. S., Purimetla, N. R., Mohan, B. K., & Harinadh, T. (2025, June). Analysing User Perceptions of Trust in Financial Systems Using Explainable AI. In 2025 Second International Conference on Networks and Soft Computing (ICNSoC) (pp. 26-30). IEEE.
- [42] Burra, R. S., APCV, G. R., & Vellela, S. S. (2024). Strategic Insights: Unleashing the Power of Big Data Analytics for Credit Investigation and Risk Mitigation in Commercial Banking. *International Journal of Progressive Research in Engineering Management and Science*, 4(01), 458-464.
- [43] Vellela, S. S., Purimetla, N. R., Vindhya, A. S., Vullam, N. R., Srinivas, B. R., & Vuyyuru, L. R. (2025, October). Design and Simulation of Quantum Error Correction Codes for Scalable Quantum Architectures. In 2025 7th International Conference on Innovative Data Communication Technologies and Application (ICIDCA) (pp. 1570-1575). IEEE.
- [44] Devana, V. K. R., Beno, A., Devadoss, C. P., Sukanya, Y., Ravi Sankar, C. V., Balamuralikrishna, P., ... & Babu, K. V. (2024). A compact self isolated MIMO UWB antenna with band notched characteristics. *IETE Journal of Research*, 70(8), 6677-6688.
- [45] Potti, Dr Balamuralikrishna. "Characteristic Mode Analysis of Two Port Semi-circular Arc-Shaped Multiple-Input-Multiple-Output Antenna With High Isolation for 5G Sub-6 GHz and Wireless Local Area Network Applications." *Int J Commun Syst* (2022): e5257.
- [46] Srija, V., & Krishna, P. B. M. (2015). Implementation of agricultural automation system using web & gsm technologies. *International Journal of Research in Engineering and Technology*, 4(09), 385-389.
- [47] Potti, B., Subramanyam, M. V., & Prasad, K. S. (2013). A packet priority approach to mitigate starvation in wireless mesh network with multimedia traffic. *International Journal of Computer Applications*, 62(14).
- [48] Potti, B., Subramanyam, M. V., & Satya Prasad, K. (2016). Adopting Multi-radio Channel Approach in TCP Congestion Control Mechanisms to Mitigate Starvation in Wireless Mesh Networks. In *Information Science and Applications (ICISA) 2016* (pp. 85-95). Springer Singapore.
- [49] Potti, D. B., MV, D. S., & Kodati, D. S. P. (2015). Hybrid genetic optimization to mitigate starvation in wireless mesh networks. *Hybrid Genetic Optimization to Mitigate Starvation in Wireless Mesh Networks*, *Indian Journal of Science and Technology*, 8(23).
- [50] Devana, V. K. R., Beno, A., Alzaidi, M. S., Krishna, P. B. M., Divyamrutha, G., Awan, W. A., ... & Alathbah, M. (2024). A high bandwidth dimension ratio compact super wide band-flower slotted microstrip patch antenna for millimeter wireless applications. *Heliyon*, 10(1).
- [51] Doss, B., Balamuralikrishna, P., Nagaraju, C. H., Lakshmaiah, D., & Naresh, S. Blockchain-Based Secure Big Data Storage on the Cloud. In *Blockchain Technology for IoT and Wireless Communications* (pp. 11-18). CRC Press.
- [52] Kapileswar, N. and Simon, J., 2025, October. A Hybrid Acoustic-Optical Communication Technique for Ultra-Low Latency Underwater IoT Network. In 2025 2nd International Conference on Electronic Circuits and Signaling Technologies (ICECST) (pp. 468-473). IEEE.
- [53] Simon, J. and Kapileswar, N., 2025, June. Federated deep learning-driven cloud-IoT framework for real-time healthcare monitoring and privacy-preserving anomaly detection. In 2025 3rd International Conference on Self Sustainable Artificial Intelligence Systems (ICSSAS) (pp. 1866-1871). IEEE.
- [54] Kapileswar, N. and Simon, J., 2025, June. Quantum-Resilient Consensus Mechanisms for Scalable Blockchain Networks using Lattice-based Cryptography. In 2025 6th International Conference on Intelligent Communication Technologies and Virtual Mobile Networks (ICICV) (pp. 1849-1854). IEEE.
- [55] Kapileswar, N. and Simon, J., 2025, August. DeepCurrent: An Attention-Driven Graph Neural Network for Energy-Efficient Routing and Data Aggregation in UIoT Networks. In 2025 International Conference on Modern Sustainable Systems (CMSS) (pp. 716-720). IEEE.
- [56] Sathish, K., 2025, February. Dynamic Topology Optimizing Magnetic Circuits for Underwater Systems for Improved Performance and Efficiency. In 2025 International Conference on Electronics and Renewable Systems (ICEARS) (pp. 433-438). IEEE.
- [57] Sathish, K., 2025, September. Adaptive Fusion and Feature Refinement for Visibility Enhancement in Turbid Underwater Scenes. In 2025 3rd International Conference on Intelligent Cyber Physical Systems and Internet of Things (ICoICI) (pp. 456-460). IEEE.
- [58] D. N. Ravikiran and C. G. Dethe, "Improvements in routing algorithms to enhance lifetime of wireless sensor networks," *Int. J. Comput. Netw. Commun.*, vol. 10, no. 2, pp. 23–32, 2018.
- [59] R. Thommandru and R. Saravanakumar, "Performance analysis of circularly polarised MIMO antenna for wireless applications," in *Proc. ICICNIS, IEEE*, Dec. 2024, pp. 513–518.
- [60] D. N. Ravikiran et al., "Secure visual data processing: Image encryption and decryption through reversible logic gates in VLSI design," *Int. J. Mod. Trends Sci. Technol.*, vol. 10, no. 2, 2024.
- [61] R. Saravanakumar et al., "Cross scoop fractal antenna design with notch at 15 degree for emerging applications at 5.2 GHz," in *Proc. RAEEUCCI, IEEE*, Apr. 2024, pp. 1–7.