



IOT based soil nutrient and pH level monitoring and analyzing system using ESP8266 and web-based monitoring

Khader Basha Sk, J. Sri Durga Devi, K. Manoj Kumar, K. Ravi Venkata Naveen, A. Purna Mallikharjuna Rao

Department of CSE – Data Science, Chalapathi Institute of Technology, Guntur-522016, A.P, India

To Cite this Article

Khader Basha Sk, J. Sri Durga Devi, K. Manoj Kumar, K. Ravi Venkata Naveen & A. Purna Mallikharjuna Rao (2026). IOT based soil nutrient and pH level monitoring and analyzing system using ESP8266 and web-based monitoring. International Journal for Modern Trends in Science and Technology, 12(SI01), 1049-1054. <https://doi.org/10.5281/zenodo.19613524>

Article Info

Received: 12 March 2026; Revised: 07 April 2026; Accepted: 10 April 2026.

Copyright © The Authors ; This is an open access article distributed under the [Creative Commons Attribution License](#), which permits unrestricted use, distribution, and reproduction in any medium, provided the original work is properly cited.

KEYWORDS

Internet of Things (IoT), Soil Monitoring, pH Level Detection, Soil Nutrient Analysis, ESP8266, Smart Agriculture

ABSTRACT

In modern agriculture, maintaining optimal soil health is essential for improving crop productivity and ensuring sustainable farming practices. Traditional methods of soil testing involve manual sample collection and laboratory analysis, which are time-consuming, costly and do not provide real-time insights. Farmers often lack continuous information about critical soil parameters such as nutrient and pH level, leading to improper fertilizer usage and reduced crop yield. To address these challenges, the integration of internet of things(iot)technology with embedded systems has emerged as an efficient solution for real-time soil monitoring and analysis. The this paper presents an iot-based soil nutrient and ph level monitoring and analyzing system using esp8266, designed to provide continuous and accurate monitoring of soil conditions. The system utilizes various sensors to measure essential soil parameters, including ph levels and nutrient indicators. These sensors are interfaced with the esp8266 microcontroller, which processes the collected data and transmits it to a web-based dashboard through wi-fi connectivity. The use of iot enables remote access to real-time soil data, allowing farmers and agricultural experts to monitor field conditions from anywhere.the implementation of this system offers several advantages, including reduced manual effort, improved accuracy, and real-time decision-making support. It enables precision agriculture by ensuring optimal soil conditions for crop growth, ultimately leading to increased productivity and resource efficiency. The system is cost-effective, scalable, and suitable for both small-scale and large-scale farming applications. Furthermore, it demonstrates the potential of iot and embedded technologies in transforming traditional agricultural practices into smart and automated systems.

1. INTRODUCTION

Agriculture plays a vital role in the economic development of many countries, and maintaining soil health is one of the most critical factors influencing crop productivity. Soil contains essential nutrients required for plant growth, and its pH level directly affects the availability of these nutrients. Traditional soil testing methods involve collecting samples and analyzing them in laboratories, which is time-consuming, expensive, and does not provide real-time information. As a result, farmers often make decisions based on assumptions rather than accurate data, leading to inefficient use of fertilizers and reduced crop yield [1].

In recent years, advancements in embedded systems and Internet of Things (IoT) technologies have provided new opportunities for smart agriculture. IoT enables continuous monitoring and real-time data collection from agricultural fields, allowing farmers to make informed decisions. Sensors can be used to measure important soil parameters such as pH level and nutrient content, and this data can be transmitted wirelessly to cloud-based platforms for analysis and visualization. Such systems reduce manual effort and improve the accuracy and efficiency of soil management practices [2]. Additionally, the system provides analysis of soil conditions to determine whether the soil is suitable for cultivation or requires treatment. Based on the sensor data, farmers can take corrective actions such as adjusting fertilizer usage or improving soil quality. The inclusion of display units and alert mechanisms further enhances usability by providing instant feedback and notifications.

Overall, the proposed system offers a smart, efficient, and cost-effective solution for modern agriculture. It supports precision farming by ensuring optimal soil conditions, reducing resource wastage, and increasing crop productivity. The integration of IoT with soil monitoring systems represents a significant step toward sustainable and technology-driven agricultural practices [1][2].

2. REVIEW LITERATURE SURVEY

Recent advancements in smart agriculture have focused on automation and real-time monitoring using embedded systems and Internet of Things (IoT) technologies. Traditional soil testing methods rely on manual sampling and laboratory analysis, which are

time-consuming, costly, and do not provide real-time insights. These limitations often lead to improper fertilizer usage, poor soil management, and reduced agricultural productivity [1].

To overcome these challenges, several researchers have proposed sensor-based soil monitoring systems. Soil pH sensors and nutrient sensors are widely used to measure soil conditions directly in the field. These systems provide accurate readings; however, some implementations require complex hardware setups and frequent calibration, making them less suitable for small-scale farmers [2].

In recent years, IoT-based soil monitoring systems have gained significant attention. These systems use microcontrollers and sensors to collect real-time soil data and transmit it to cloud platforms for monitoring and analysis. Some studies have implemented Raspberry Pi-based systems integrated with advanced data analytics and machine learning techniques to predict soil fertility and crop suitability. While these approaches improve accuracy, they increase system complexity and cost [3].

Alternatively, ESP8266-based systems have been proposed as a simple, cost-effective, and efficient solution for soil monitoring. With built-in Wi-Fi capability, ESP8266 enables real-time data transmission without requiring additional communication modules. These systems are easy to deploy and suitable for both small and medium-scale agricultural applications.

Furthermore, wireless communication and IoT platforms have been widely used to provide real-time updates and alerts to farmers. Users can monitor soil conditions remotely through mobile or web applications, improving decision-making and resource management..

Based on the reviewed literature, it is evident that a combination of soil sensors, ESP8266, and IoT communication offers a low-cost, efficient, and reliable solution for real-time soil nutrient and pH monitoring. The proposed system builds upon these approaches to provide an optimized and practical implementation for smart agriculture [1][2][3][4].

3. RESEARCH METHODOLOGY

The proposed system is designed to monitor soil nutrient levels and pH values using sensors, ESP8266 microcontroller, LCD display, and IoT communication. The methodology focuses on sensing soil parameters,

processing the data, and updating the information in real time.

A. System Design

The system consists of soil pH sensors and nutrient sensors placed in the soil to measure various parameters. These sensors are connected to the ESP8266, which acts as the central processing unit.

B. Data Acquisition

The continuously measure soil conditions such as pH level and nutrient content. The collected data reflects the current status of soil health.

C. Data Processing

The ESP8266 processes the sensor data and compares it with predefined threshold values. Based on this comparison, it determines whether the soil condition is optimal, acidic, or alkaline.

D. Display Unit

An I2C LCD module is used to display real-time information such as soil pH value and nutrient status. This allows users to monitor soil conditions locally.

E. Alert Mechanism

The system uses IoT communication to update soil data remotely. Users can access this information through a mobile or web dashboard, enabling real-time monitoring and alerts when soil conditions are not suitable.

4. PROPOSED METHODOLOGY

The proposed system presents a smart and automated approach for soil monitoring using sensors, ESP8266, LCD display, and IoT technology. The system continuously measures soil pH and nutrient levels and provides real-time updates.

In this methodology, sensors are embedded in the soil to detect pH levels and nutrient conditions. When changes occur in soil properties, the sensors capture the data and send it to the ESP8266.

The ESP8266 acts as the central processing unit, analyzing the received data and comparing it with predefined threshold values to determine soil condition. Based on this analysis, the system identifies whether the soil is suitable for cultivation or requires treatment.

An I2C LCD module displays real-time soil data locally, allowing farmers to monitor conditions easily. Additionally, IoT connectivity enables remote access to soil data through web or mobile applications.

Whenever soil conditions change, the system updates the information instantly. This ensures accurate and

real-time monitoring, helping farmers take timely actions such as applying fertilizers or adjusting soil treatment.

The system operates continuously without manual intervention, making it suitable for modern precision agriculture.

WORKING PRINCIPLE

working principle of the proposed system is based on real-time sensing and monitoring of soil parameters. The system uses sensors to continuously measure soil pH levels and nutrient content.

Initially, the sensors detect soil conditions and generate corresponding electrical signals. These signals are sent to the ESP8266 microcontroller for processing.

The ESP8266 analyzes the sensor data and compares it with predefined threshold values to determine soil status. If the pH value is too high or too low, the system identifies the soil as alkaline or acidic, respectively.

The real-time soil status is displayed on the LCD module for local monitoring. At the same time, the system sends data to an IoT platform via Wi-Fi, allowing users to monitor soil conditions remotely.

The process is repeated continuously, ensuring accurate and up-to-date information. Thus, the system provides an efficient and automated solution for soil monitoring by combining sensing, processing, display, and communication technologies.

BLOCK DIAGRAM

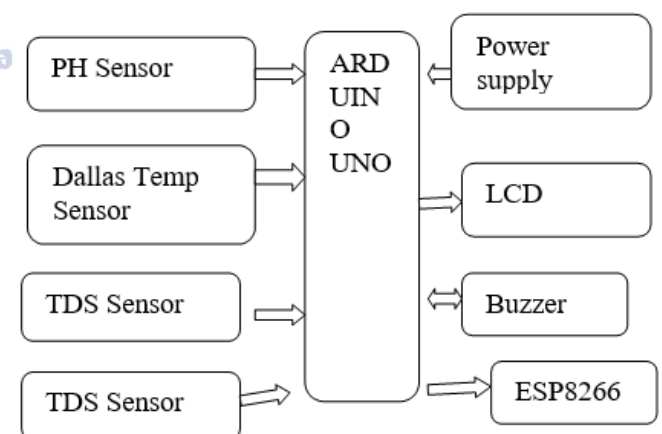

Fig 4.1: Block Diagram

5. RESULTS AND OUTCOMES

The proposed IoT-based soil monitoring system was successfully designed and implemented using soil sensors, ESP8266, LCD display, and IoT connectivity.

The system was tested under different soil conditions to evaluate its performance.

The sensors accurately measured soil pH levels and nutrient conditions. The ESP8266 processed the data efficiently and displayed real-time values on the LCD.

When soil conditions changed, the system updated the data instantly through IoT platforms, enabling real-time monitoring and quick decision-making.

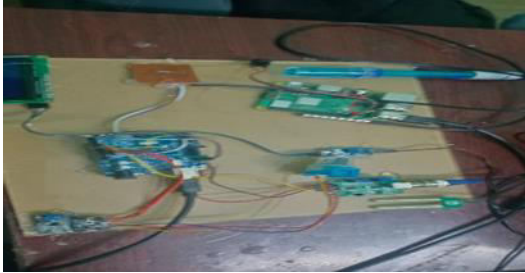

Fig. 5.1: Output 1

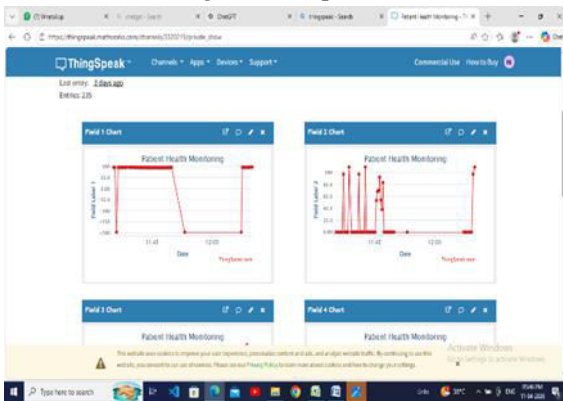

Fig. 5.2: Output 2

The overall system performance was stable, accurate, and reliable. It reduced manual effort and provided continuous monitoring of soil health. The outcomes demonstrate that the system significantly improves agricultural efficiency and decision-making.

6. CONCLUSION

The proposed IoT-Based Soil Nutrient and pH Level Monitoring and Analyzing System using ESP8266 was successfully implemented and tested. The system effectively monitored soil conditions and provided real-time updates using sensor and IoT technologies.

The ESP8266 processed sensor data efficiently, while the LCD display enabled local monitoring. IoT functionality allowed remote access to soil information, improving farmer awareness and decision-making.

The system demonstrated reliable performance, reduced manual soil testing, and improved fertilizer

management. It is cost-effective and suitable for both small and large-scale farming applications.

In conclusion, the proposed system provides a smart, efficient, and scalable solution for modern agriculture. It highlights the importance of integrating IoT and embedded systems for precision farming and sustainable agricultural practices.

Conflict of interest statement

Authors declare that they do not have any conflict of interest.

REFERENCES

- [1] K. K. Kommineni and A. Prasad, "A Review on Privacy and Security Improvement Mechanisms in MANETs", *Int J Intell Syst Appl Eng*, vol. 12, no. 2, pp. 90–99, Dec. 2023.
- [2] Kommineni, K.K., Prasad, A. Enhancing Data Security and Privacy in SDN-Enabled MANETs Through Improved Data Aggregation Protection and Secrecy. *Wireless Pers Commun* 139, 855–882 (2024). <https://doi.org/10.1007/s11277-024-11635-w>
- [3] "Blockchain-Enabled Secure Data Aggregation for SDN-Enabled Ad-Hoc Networks," *International Journal of Intelligent Engineering and Systems*, vol. 18, no. 5, pp. 704–717, Jun. 2025, doi: <https://doi.org/10.22266/ijies2025.0630.49>.
- [4] K. K. Kommineni, P. Ande, "Blockchain-driven key management and privacy-preserving data Aggregation Scheme for SDN-enabled MANETs," *International Journal of Intelligent Engineering and Systems*, vol. 18–18, no. 9, pp. 601–615, 2025, doi: [10.22266/ijies2025.1031.39](https://doi.org/10.22266/ijies2025.1031.39).
- [5] Kumar, K. K., Kumar, S. G. B., Rao, S. G. R., & Sydulu, S. S. J. (2017, November). Safe and high secured ranked keyword searchover an outsourced cloud data. In *2017 International Conference on Inventive Computing and Informatics (ICICI)* (pp. 20-25). IEEE.
- [6] K. K. Kommineni, S. J. Basha, M. Sandeep, P. S. Vadana, T. S. R. Sai and D. S. Kumar, "A Review on IoT-based Defensive Devices for Women Security," *2023 9th International Conference on Advanced Computing and Communication Systems (ICACCS)*, Coimbatore, India, 2023, pp. 99-104, doi: [10.1109/ICACCS57279.2023.10113015](https://doi.org/10.1109/ICACCS57279.2023.10113015).
- [7] Vellela, S. S., & Balamaniandan, R. (2024). Optimized clustering routing framework to maintain the optimal energy status in the wsn mobile cloud environment. *Multimedia Tools and Applications*, 83(3), 7919-7938.
- [8] Vellela, S. S., & Balamaniandan, R. (2023). An intelligent sleep-awake energy management system for wireless sensor network. *Peer-to-Peer Networking and Applications*, 16(6), 2714-2731.
- [9] Vellela, S. S., & Balamaniandan, R. (2022, December). Design of Hybrid Authentication Protocol for High Secure Applications in Cloud Environments. In *2022 International Conference on Automation, Computing and Renewable Systems (ICACRS)* (pp. 408-414). IEEE.
- [10] Vellela, S. S., Balamaniandan, R., & Praveen, S. P. (2022). Strategic survey on security and privacy methods of cloud computing environment. *Journal of Next Generation Technology*, 2(1).
- [11] Reddy, N. V. R. S., Chitteti, C., Yesupadam, S., Desanamukula, V. S., Vellela, S. S., & Bommagani, N. J. (2023). Enhanced Speckle Noise Reduction in Breast Cancer Ultrasound Imagery Using a

- Hybrid Deep Learning Model. *Ingenierie des Systemes d'Information*, 28(4), 1063.
- [12] Vellela, S. S., & Balamanigandan, R. (2024). An efficient attack detection and prevention approach for secure WSN mobile cloud environment. *Soft Computing*, 28(19), 11279-11293.
- [13] Polasi, P. K., Vellela, S. S., Narayana, J. L., Simon, J., Kapileswar, N., Prabu, R. T., & Rashed, A. N. Z. (2026). Data rates transmission, operation performance speed and figure of merit signature for various quadrature light sources under spectral and thermal effects. *Journal of Optics*, 55(1), 633-643.
- [14] Vellela, S. S., & Krishna, A. M. (2020). On Board Artificial Intelligence With Service Aggregation for Edge Computing in Industrial Applications. *Journal of Critical Reviews*, 7(07).
- [15] Vellela, S. S., Rao, M. V., Mantena, S. V., Reddy, M. J., Vatambeti, R., & Rahman, S. Z. (2024). Evaluation of Tennis Teaching Effect Using Optimized DL Model with Cloud Computing System. *International Journal of Modern Education and Computer Science (IJMECS)*, 16(2), 16-28.
- [16] Biyyapu, N., Veerapaneni, E. J., Surapaneni, P. P., Vellela, S. S., & Vatambeti, R. (2024). Designing a modified feature aggregation model with hybrid sampling techniques for network intrusion detection. *Cluster Computing*, 27(5), 5913-5931.
- [17] Vuyyuru, L. R., Purimetla, N. R., Reddy, K. Y., Vellela, S. S., Basha, S. K., & Vatambeti, R. (2025). Advancing automated street crime detection: a drone-based system integrating CNN models and enhanced feature selection techniques. *International Journal of Machine Learning and Cybernetics*, 16(2), 959-981.
- [18] Praveen, S. P., Vellela, S. S., & Balamanigandan, R. (2024). SmartIris ML: harnessing machine learning for enhanced multi-biometric authentication. *Journal of Next Generation Technology (ISSN: 2583-021X)*, 4(1).
- [19] Vellela, S. S., Roja, D., Purimetla, N. R., Thalakola, S., Vuyyuru, L. R., & Vatambeti, R. (2025). Cyber threat detection in industry 4.0: Leveraging GloVe and self-attention mechanisms in BiLSTM for enhanced intrusion detection. *Computers and Electrical Engineering*, 124, 110368.
- [20] Vellela, S. S., Varshini, K., Jeevana, M., Kadheer, S. K., & Kumar, T. P. (2024). Iot based smart irrigation and controlling system. *IoT Based Smart Irrigation and Controlling System*, *International Journal for Modern Trends in Science and Technology*, 10(02), 77-85.
- [21] Vellela, S. S., Manne, V. K., Trividha, G., Chaithanya, L., & Shaik, A. (2025). Intelligent transportation systems ai and iot for sustainable urban traffic management. Available at SSRN 5250812.
- [22] Vindhya, A. S., Vellela, S. S., Malathi, N., Vullam, N. R., Vuyyuru, L. R., & Rao, T. (2025, September). Integrating Quantum Computing with Genomic Data Analysis: A Next-Generation Approach for Predicting Disease Susceptibility. In 2025 4th International Conference on Innovative Mechanisms for Industry Applications (ICIMIA) (pp. 1168-1173). IEEE.
- [23] Vellela, S. S., Rao, M. V., Krishna, C. V. M., Rao, T. S., & Dasthvejula, R. (2026). Piezoelectric and Shape-Memory Materials for Actuators and Energy Harvesting in Mechanical, Electronics, and Biomedical Engineering Using AI-Based Design. In *Advanced Materials for Biomedical Devices* (pp. 195-206). CRC Press.
- [24] Vellela, S. S., Malathi, N., Vuyyuru, L. R., Javvadi, S., Rao, T. S., Bindu, M. N. H., & Rao, K. N. (2025, August). Improving Medical Image Analysis with Convolutional Neural Networks (Cnns). In 2025 International Conference on Intelligent and Secure Engineering Solutions (CISES) (pp. 579-584). IEEE.
- [25] Roja, D., Jidugu, S. K., Rao, T. S., Vuyyuru, L. R., Vellela, S. S., & Ranjani, B. S. (2025, December). High-Fidelity Image Synthesis using Enhanced Generative Adversarial Networks with Attention Mechanisms. In 2025 International Conference on NexGen Networks and Cybernetics (IC2NC) (pp. 885-890). IEEE.
- [26] Pakalapati, S., Rani, C. J., Vellela, S. S., Thanuja, N., & Bindu, M. N. H. (2025, November). Progressive GAN-based Framework for Realistic Image Generation and Style Transfer. In 2025 5th International Conference on Evolutionary Computing and Mobile Sustainable Networks (ICECMSN) (pp. 474-479). IEEE.
- [27] Yanamadala, N., & Vellela, S. S. (2025, June). Ensuring Authenticity and Confidentiality in Images using SHA-ECC Fusion. In 2025 Second International Conference on Networks and Soft Computing (ICNSoC) (pp. 684-689). IEEE.
- [28] Rao, M. V., Sreeraman, Y., Mantena, S. V., Gundu, V., Roja, D., & Vatambeti, R. (2024). Brinjal Crop yield prediction using Shuffled shepherd optimization algorithm based ACNN-OBDLSTM model in Smart Agriculture. *Journal of Integrated Science and Technology*, 12(1), 710-710.
- [29] Reddy, B. V., Kumar, A. H., Gopi, C., Prasad, Y. V. D., Vellela, S. S., & Roja, D. (2025, April). Machine learning based automated liver fibrosis stage diagnosis with prediction. In 2025 International Conference on Advances in Modern Age Technologies for Health and Engineering Science (AMATHE) (pp. 1-6). IEEE.
- [30] Burra, R. S., APCV, G. R., & Vellela, S. S. (2024). Enhancing Ddos Detection Through Semi-Supervised Machine Learning: A Novel Approach for Improved Network Security. *International Research Journal of Modernization in Engineering Technology and Science*, 6.
- [31] Vellela, S. S., Vullam, N. R., Gorintla, S., Rao, T. S., & Harinadh, T. (2025, July). Exploring the Anti-Inflammatory Potential of Green-Synthesized Pyrazolines. In 2025 6th International Conference on Data Intelligence and Cognitive Informatics (ICDICI) (pp. 814-819). IEEE.
- [32] Vellela, S. S., Chandra, S. S., Thommandru, R., Mastan Basha, S., & Sri Ram, D. (2023). Novel Approach to Mitigate Starvation in Wireless Mesh Networks. Available at SSRN 5262254.
- [33] Praveen, S. P., Vellela, S. S., Sharma, K., & Dalavai, L. Quantitative Evaluation of Smart Textile Adoption in Rural Weaving Communities using Machine Learning. *Journal of the Textile Association*, 86(3), 277-284.
- [34] Mandava, R., Dalavai, L., Vellela, S. S., Purimetla, N. R., Mohan, B. K., & Harinadh, T. (2025, June). An In-Depth Study on the Integration of Explainable AI Techniques to Enhance Interpretability in Clinical Risk Prediction Models. In 2025 Second International Conference on Networks and Soft Computing (ICNSoC) (pp. 43-47). IEEE.
- [35] Rao, M. V., Krishna, C. V. M., Vellela, S. S., Vara, J., Paul, K. J., & Rao, K. N. (2025, March). Enhancement and Blind Image Restoration for Quality Improvements of Camera Captured Pictures/Videos. In 2025 7th International Conference on Intelligent Sustainable Systems (ICISS) (pp. 791-796). IEEE.
- [36] Vellela, S. S., Anusha, P., Vullam, N. R., Jala, J., Bellapu, V. S., & Vindhya, A. S. (2025, October). Quantum Cryptography and Key Distribution for Secure Communication in the Post Quantum World. In 2025 International Conference on Sustainable Communication Networks and Application (ICSCN) (pp. 619-624). IEEE.
- [37] Vellela, S. S., Vuyyuru, L. R., Jidugu, S. K., Rao, M. P., & Srinivas, B. R. (2025, November). The Impact Of Quantum Computing On Blockchain Security And Quantum Resistant Protocols. In 2025 2nd International Conference on Intelligent Systems for Cybersecurity (ISCS) (pp. 1-6). IEEE.
- [38] Kumar, M. S., Vellela, S. S., Gorintla, S., Malathi, N., Rao, T. S., & Rani, N. R. (2025, October). Intelligent Resource Allocation in Wireless Sensor Networks: A Hybrid Optimization Approach for Energyconstrained Environments. In 2025 2nd International Conference on Electronic Circuits and Signaling Technologies (ICECST) (pp. 724-729). IEEE.
- [39] Krishna, T. V., Rani, N. R., Ranjani, B. S., & Vellela, S. S. (2025). Distributed Big-Data Analytics with PySpark for Personalized

- Restaurant Recommendation Systems. *Journal of Next Generation Technology* (ISSN: 2583-021X), 5(6).
- [40] Harinadh, T., Anusha, P., Roja, D., Vellela, S. S., & Muthukumar, P. (2025). PySpark Orchestrated Machine Learning Paradigms for Advanced Network Intrusion Detection. *Journal of Next Generation Technology* (ISSN: 2583-021X), 5(6).
- [41] Mandava, R., Hariitha, K., Vellela, S. S., Purimetla, N. R., Mohan, B. K., & Harinadh, T. (2025, June). Analysing User Perceptions of Trust in Financial Systems Using Explainable AI. In 2025 Second International Conference on Networks and Soft Computing (ICNSoC) (pp. 26-30). IEEE.
- [42] Burra, R. S., APCV, G. R., & Vellela, S. S. (2024). Strategic Insights: Unleashing the Power of Big Data Analytics for Credit Investigation and Risk Mitigation in Commercial Banking. *International Journal of Progressive Research in Engineering Management and Science*, 4(01), 458-464.
- [43] Vellela, S. S., Purimetla, N. R., Vindhya, A. S., Vullam, N. R., Srinivas, B. R., & Vuyyuru, L. R. (2025, October). Design and Simulation of Quantum Error Correction Codes for Scalable Quantum Architectures. In 2025 7th International Conference on Innovative Data Communication Technologies and Application (ICIDCA) (pp. 1570-1575). IEEE.
- [44] Devana, V. K. R., Beno, A., Devadoss, C. P., Sukanya, Y., Ravi Sankar, C. V., Balamuralikrishna, P., ... & Babu, K. V. (2024). A compact self isolated MIMO UWB antenna with band notched characteristics. *IETE Journal of Research*, 70(8), 6677-6688.
- [45] Potti, Dr Balamuralikrishna. "Characteristic Mode Analysis of Two Port Semi-circular Arc-Shaped Multiple-Input-Multiple-Output Antenna With High Isolation for 5G Sub-6 GHz and Wireless Local Area Network Applications." *Int J Commun Syst* (2022): e5257.
- [46] Srija, V., & Krishna, P. B. M. (2015). Implementation of agricultural automation system using web & gsm technologies. *International Journal of Research in Engineering and Technology*, 4(09), 385-389.
- [47] Potti, B., Subramanyam, M. V., & Prasad, K. S. (2013). A packet priority approach to mitigate starvation in wireless mesh network with multimedia traffic. *International Journal of Computer Applications*, 62(14).
- [48] Potti, B., Subramanyam, M. V., & Satya Prasad, K. (2016). Adopting Multi-radio Channel Approach in TCP Congestion Control Mechanisms to Mitigate Starvation in Wireless Mesh Networks. In *Information Science and Applications (ICISA) 2016* (pp. 85-95). Springer Singapore.
- [49] Potti, D. B., MV, D. S., & Kodati, D. S. P. (2015). Hybrid genetic optimization to mitigate starvation in wireless mesh networks. *Hybrid Genetic Optimization to Mitigate Starvation in Wireless Mesh Networks*, *Indian Journal of Science and Technology*, 8(23).
- [50] Devana, V. K. R., Beno, A., Alzaidi, M. S., Krishna, P. B. M., Divyamrutha, G., Awan, W. A., ... & Alathbah, M. (2024). A high bandwidth dimension ratio compact super wide band-flower slotted microstrip patch antenna for millimeter wireless applications. *Heliyon*, 10(1).
- [51] Doss, B., Balamuralikrishna, P., Nagaraju, C. H., Lakshmaiah, D., & Naresh, S. Blockchain-Based Secure Big Data Storage on the Cloud. In *Blockchain Technology for IoT and Wireless Communications* (pp. 11-18). CRC Press.
- [52] Kapileswar, N. and Simon, J., 2025, October. A Hybrid Acoustic-Optical Communication Technique for Ultra-Low Latency Underwater IoT Network. In 2025 2nd International Conference on Electronic Circuits and Signaling Technologies (ICECST) (pp. 468-473). IEEE.
- [53] Simon, J. and Kapileswar, N., 2025, June. Federated deep learning-driven cloud-IoT framework for real-time healthcare monitoring and privacy-preserving anomaly detection. In 2025 3rd International Conference on Self Sustainable Artificial Intelligence Systems (ICSSAS) (pp. 1866-1871). IEEE.
- [54] Kapileswar, N. and Simon, J., 2025, June. Quantum-Resilient Consensus Mechanisms for Scalable Blockchain Networks using Lattice-based Cryptography. In 2025 6th International Conference on Intelligent Communication Technologies and Virtual Mobile Networks (ICICV) (pp. 1849-1854). IEEE.
- [55] Kapileswar, N. and Simon, J., 2025, August. DeepCurrent: An Attention-Driven Graph Neural Network for Energy-Efficient Routing and Data Aggregation in UIoT Networks. In 2025 International Conference on Modern Sustainable Systems (CMSS) (pp. 716-720). IEEE.
- [56] Sathish, K., 2025, February. Dynamic Topology Optimizing Magnetic Circuits for Underwater Systems for Improved Performance and Efficiency. In 2025 International Conference on Electronics and Renewable Systems (ICEARS) (pp. 433-438). IEEE.
- [57] Sathish, K., 2025, September. Adaptive Fusion and Feature Refinement for Visibility Enhancement in Turbid Underwater Scenes. In 2025 3rd International Conference on Intelligent Cyber Physical Systems and Internet of Things (ICoICI) (pp. 456-460). IEEE.
- [58] D. N. Ravikiran and C. G. Dethé, "Improvements in routing algorithms to enhance lifetime of wireless sensor networks," *Int. J. Comput. Netw. Commun.*, vol. 10, no. 2, pp. 23–32, 2018.
- [59] R. Thommandru and R. Saravanakumar, "Performance analysis of circularly polarised MIMO antenna for wireless applications," in *Proc. ICICNIS, IEEE*, Dec. 2024, pp. 513–518.
- [60] D. N. Ravikiran et al., "Secure visual data processing: Image encryption and decryption through reversible logic gates in VLSI design," *Int. J. Mod. Trends Sci. Technol.*, vol. 10, no. 2, 2024.
- [61] R. Saravanakumar et al., "Cross scoop fractal antenna design with notch at 15 degree for emerging applications at 5.2 GHz," in *Proc. RAEEUCCI, IEEE*, Apr. 2024, pp. 1–7.