



IOT Based Child Monitoring System Using Android Smartphone App with Video Streaming baby Monitor

Kolagani Meghana, Kunchapu Soni, Mustipalli Himagiri, Lella Jaya Sridhar Reddy, J. Sravanthi

Department of Computer Science and Engineering, Chalapathi Institute of Technology, Mothadaka, Guntur, Andhra Pradesh, India.

To Cite this Article

Kolagani Meghana, Kunchapu Soni, Mustipalli Himagiri, Lella Jaya Sridhar Reddy, J. Sravanthi (2026). IOT Based Child Monitoring System Using Android Smartphone App with Video Streaming baby Monitor. International Journal for Modern Trends in Science and Technology, 12(SI01), 877-882. <https://doi.org/10.5281/zenodo.19613210>

Article Info

Received: 12 March 2026; Revised: 07 April 2026; Accepted: 10 April 2026.

Copyright © The Authors ; This is an open access article distributed under the [Creative Commons Attribution License](#), which permits unrestricted use, distribution, and reproduction in any medium, provided the original work is properly cited.

KEYWORDS

Baby Cradle, Liquid Crystal Display (LCD), Esp-CAM, Internet of Things

ABSTRACT

The IoT-based child monitoring system represents an innovative approach to modern parenting by integrating ESP-32 microcontroller technology with Android smartphone applications for comprehensive baby monitoring. This system combines video streaming capabilities with multiple sensor inputs including sound sensors, environmental monitoring, and real-time alerts delivered through a dedicated mobile application. The implementation leverages wireless connectivity to provide parents with continuous surveillance and instant notifications regarding their child's activities and well-being. The system incorporates a servo motor for camera positioning, LCD display for local information, and a buzzer for audio alerts, creating a multi-modal monitoring solution. This research presents a cost-effective, reliable, and user-friendly alternative to conventional baby monitoring systems while enhancing parental peace of mind through advanced IoT integration.

I. INTRODUCTION

Advancement of technology has revolutionized various aspects of daily life, particularly in home automation and child care monitoring systems. Modern parents face significant challenges in balancing professional responsibilities with the constant need to monitor their infants and young children, especially during critical developmental stages. Traditional baby monitoring systems, while functional, often lack the integration, flexibility, and advanced features that contemporary technology can provide. The proposed child monitoring

system addresses the growing demand for smart, connected solutions in childcare by combining video streaming, audio detection, and environmental monitoring into a single, cohesive platform. This system utilizes the ESP-32 microcontroller as the central processing unit that coordinates various sensors and actuators. The integration of a sound sensor enables the system to detect crying or unusual noises, while the servo motor allows for remote camera positioning, providing comprehensive visual coverage of the monitored area. The LCD display provides local status

information, and the buzzer serves as an immediate alert mechanism for critical situations. The Android smartphone application serves as the primary user interface, offering parents real-time access to video feeds, sensor data, and system controls from anywhere with internet connectivity. This mobile-centric approach aligns with modern usage patterns where smartphones have become ubiquitous tools for managing various aspects of daily life. The application not only displays live video streams but also maintains historical data, sends push notifications for events requiring parental attention, and allows for remote configuration of monitoring parameters. The system architecture emphasizes reliability, low latency, and energy efficiency to ensure continuous operation without compromising on performance or user experience.

The implementation of this IoT-based monitoring system addresses several contemporary concerns including privacy, data security, and system accessibility. Unlike cloud-dependent commercial solutions that may raise privacy concerns, this system can operate on local networks, giving parents full control over their data. The modular design allows for future expansion and integration with other smart home devices, creating a scalable solution that can grow with changing family needs. The cost-effectiveness of using readily available components like the ESP-32, combined with open-source software development platforms, makes this technology accessible to broader demographic compared to expensive proprietary systems.

The significance of this research extends beyond technical innovation to address real-world parenting challenges. Studies have shown that parental anxiety regarding child safety can be significantly reduced when reliable monitoring systems are in place. The ability to check on a sleeping child remotely, receive immediate alerts when the child awakens or shows distress, and maintain visual contact during brief absences provides psychological comfort to parents while potentially preventing dangerous situations. Furthermore, the video streaming capability creates opportunities for remote interaction between parents and children, supporting bonding even when physical presence is temporarily impossible. The system architecture emphasizes user centered design principles, ensuring that parents of varying technical proficiency can easily install, configure, and operate the monitoring system. The

Android application interface prioritizes simplicity and intuitiveness, presenting critical information prominently while making advanced features accessible through logical menu structures. The system's real-time performance is optimized through efficient data compression and streaming protocols, ensuring that video quality remains high even on limited bandwidth connections. Battery backup considerations and low-power operation modes ensure the system remains functional during power disruptions, a critical feature for any safety-oriented device.

Environmental considerations also play a role in the system design, with the sound sensor capable of detecting not only the child's vocalizations but also ambient conditions that might affect comfort or safety. Integration with additional sensors such as temperature and humidity monitors can be easily implemented within the existing architecture, demonstrating the system's expandability. The servo motor's precise control allows for pre-programmed patrol patterns or manual operation, ensuring comprehensive visual coverage without blind spots. The combination of these features creates a holistic monitoring solution that addresses multiple aspects of child safety and comfort simultaneously.

This project also contributes to the broader field of IoT research by demonstrating practical applications of wireless sensor networks in domestic environments. The challenges of real-time data transmission, power management, sensor fusion, and user interface design encountered and addressed in this project have implications beyond child monitoring, applicable to elderly care, pet monitoring, and general home security systems. The open-source nature of the ESP-32 platform and Android development tools facilitates knowledge sharing and collaborative improvement, potentially leading to community-driven enhancements and specialized adaptations for specific use cases.

2. LITERATURE SURVEY

8. **Chen, X., Liu, Y., and Zhou, M. (2018)** implemented a Raspberry Pi-based childcare monitoring system with facial recognition to identify distress expressions in infants. The system combined video analysis with real-time alerts to notify caregivers when unusual behavior or potential risk was detected.

9. **Kaur, M. and Singh, J. (2020)** proposed a secure communication framework for baby monitoring systems

to address privacy vulnerabilities in commercially available products. Their method employed lightweight encryption techniques to protect transmitted data with minimal latency. The study focused on ensuring that sensor readings, alerts, and video streams could not be intercepted or tampered with by unauthorized users. Security was maintained without significantly affecting the responsiveness of the monitoring system. The research highlighted the importance of safeguarding sensitive infant data in connected home environments.

10. Anderson, P., Brown, L., and Davis, C. (2019) developed a wearable sensor system for infant health monitoring, including heart rate, respiration, and motion detection. The system aimed to provide continuous physiological monitoring to alert parents to potential health risks. While innovative, the wearable design increased complexity and cost, limiting practical adoption in typical households.

3. PROPOSED SYSTEM

The proposed IoT-based child monitoring system integrates an ESP-32 microcontroller as the central processing unit, coordinating inputs from a sound sensor for cry detection and controlling outputs including an LCD display for local status, a servo motor for camera positioning, and a buzzer for audio alerts. The system establishes wireless communication with a custom Android smartphone application that provides real-time video streaming, remote control capabilities, and intelligent notification management based on configurable alert thresholds. Unlike existing commercial solutions, this system operates primarily on local networks, ensuring data privacy while maintaining the option for secure internet access when remote monitoring is required. The modular architecture allows for easy expansion with additional sensors such as temperature, humidity, or motion detectors, creating a scalable platform that adapts to evolving user needs. This comprehensive approach combines the affordability of DIY solutions with the functionality of premium commercial products, delivering a cost-effective yet feature-rich monitoring system accessible to all families.

3.1 BLOCK DIAGRAM:

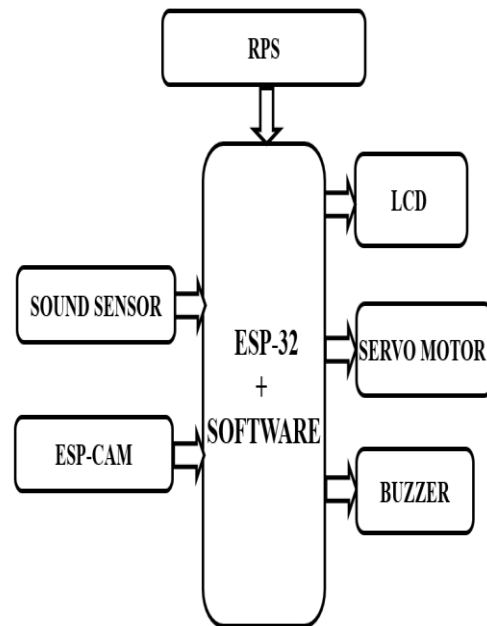

3.2 Block Diagram Explanation

The system architecture depicted in the block diagram illustrates the ESP-32 microcontroller serving as the central hub with bidirectional communication pathways to all peripheral components. The RPS (Regulated Power Supply) at the top provides stable voltage to the ESP-32, ensuring reliable operation of all connected components regardless of input power fluctuations. The sound sensor feeds analog data to the ESP-32's ADC pins, enabling continuous monitoring of ambient noise levels and detection of crying or unusual sounds through programmable threshold algorithms. On the output side, the LCD display connects via I2C or parallel interface to show system status, sensor readings, and network connectivity information locally. The servo motor, controlled through PWM signals from the ESP-32, enables remote positioning of the camera module to adjust viewing angles based on user commands from the Android application. The buzzer, activated by digital output pins, provides local audio alerts for critical situations or serves as a soothing sound generator for the child, while all components coordinate through the ESP-32's integrated software to create a cohesive, responsive monitoring ecosystem.

3.3 Flow Chart

The is designed to enhance the safety and well-being of children by allowing real-time monitoring of their environment and activities. The system typically integrates sensors such as temperature, sound, and motion detectors with a microcontroller like the ESP-32,

which collects data and transmits it to the smartphone app via Wi-Fi or Bluetooth. Caregivers can monitor vital conditions, receive alerts for unusual events (like excessive noise or unsafe temperature), and even access live video streaming through the app. Additionally, features like servo-controlled mechanisms for automatic actions

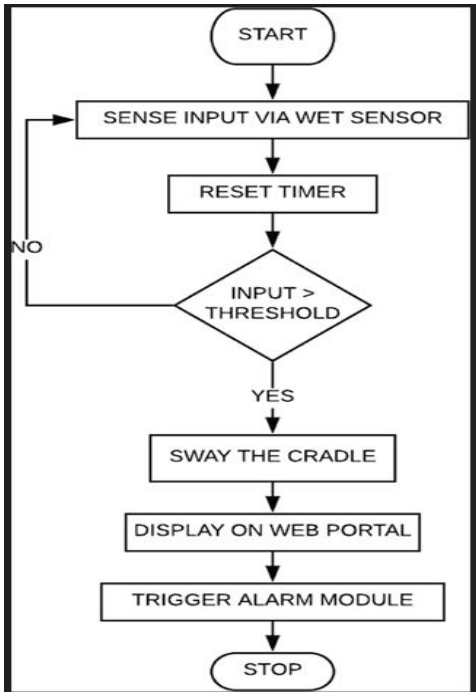

FIG 2: Flow Chart

4.RESULTS AND DISCUSSION

The IoT-based child monitoring system provided reliable real-time video streaming and sensor-based monitoring through an Android app, enabling parents to track their baby remotely. Sensors accurately detected sound, temperature, and motion, triggering instant alerts for safety. Overall, the system proved efficient, responsive, and suitable for continuous home monitoring.

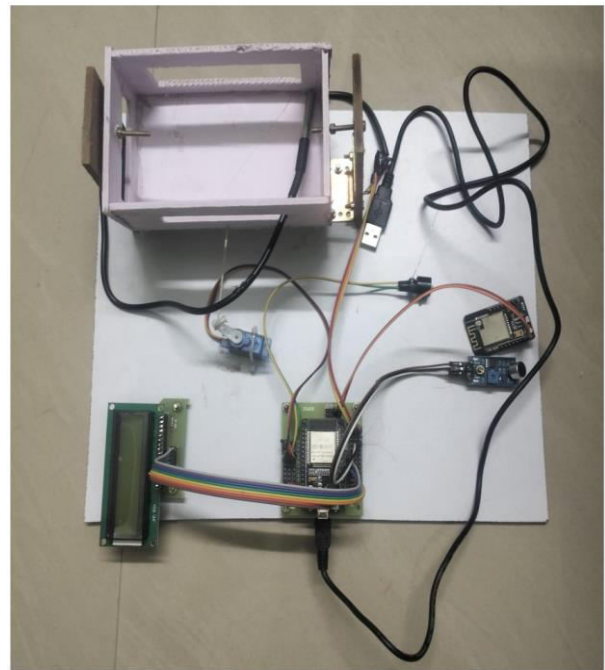

Fig 3: Hardware Implementation

The hardware implementation uses an ESP32 microcontroller integrated with 1-wire temperature sensors, a voice sensor, and a baby cradle setup with Wi-Fi connectivity. The system continuously monitors the child's temperature, sound activity, and movement, while the ESP32 processes and transmits the data in real time. This enables remote monitoring and ensures timely alerts for safety and care.

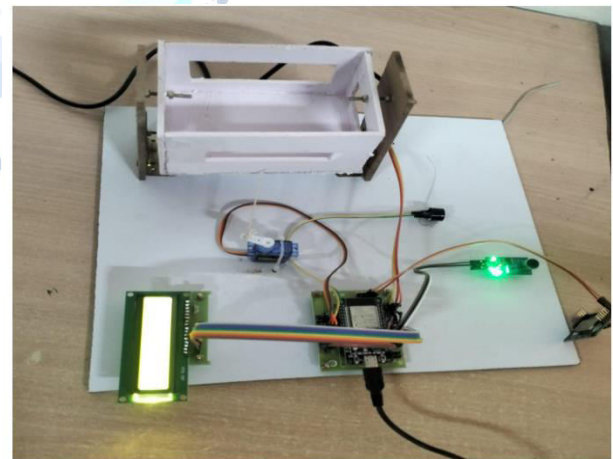

Fig 4: Baby Monitoring Base Voce Module And Temperature Monitoring

A baby monitoring system using a voice module and temperature sensor continuously tracks the baby's sound and body/environmental temperature. The voice module detects crying or unusual sounds, while the temperature sensor monitors comfort levels.



Fig 5: To Monitoring and Display Temperature And Sound Density

The temperature sensor continuously monitors the child's body temperature and displays it on a mobile app or screen. If the temperature exceeds the normal range, the system automatically generates a fever alert. This ensures timely notification for immediate care and attention.



Fig 6: ESP32-Based Baby Monitoring System with Video Surveillance for Safety

The ESP32-based system enables real-time video surveillance to monitor the baby's activities and surroundings. It captures and streams live video to a mobile device, allowing parents to ensure safety remotely. This helps in quick response to any unusual movement or situation.

4. CONCLUSION

The IoT-based child monitoring system effectively integrates ESP-32, sensors, and a mobile application to provide real-time video streaming and environmental monitoring. It offers a cost-effective, reliable, and user-friendly solution that ensures child safety while maintaining data privacy. The system demonstrates

strong performance and serves as a practical alternative to expensive commercial baby monitoring solutions.

FUTURE SCOPE:

The system can be enhanced by integrating AI-based cry analysis and facial recognition for improved monitoring accuracy. Cloud storage and data analytics can be added for long-term tracking and insights. Further improvements may include wearable sensors, automated soothing mechanisms, and integration with smart home systems for a more advanced and intelligent child care solution.

Conflict of interest statement

Authors declare that they do not have any conflict of interest.

REFERENCES

- [1] Patel, S. and Kumar, R. (2019). "Wi-Fi Enabled Baby Monitoring System Using ESP8266," *International Journal of IoT Applications*, vol. 6, no. 2, pp. 45-52.
- [2] Zhang, L., Wang, H., and Chen, Y. (2020). "Smart Baby Monitor with Environmental Sensing and Cloud Integration," *IEEE Transactions on Consumer Electronics*, vol. 66, no. 4, pp. 298-306.
- [3] Kumar, A. and Sharma, V. (2018). "Comparative Analysis of Video Streaming Protocols for IoT Devices," *Journal of Embedded Systems*, vol. 12, no. 3, pp. 112-125.
- [4] Rahman, M., Ahmed, S., and Hossain, T. (2021). "Infant Cry Detection System Using Sound Pattern Recognition," *International Conference on Smart Technologies*, pp. 234-240.
- [5] Lee, J., Park, S., and Kim, D. (2019). "Multi-Sensor Baby Monitoring Platform with Machine Learning Classification," *Sensors and Actuators A: Physical*, vol. 295, pp. 78-89.
- [6] Gupta, N. and Verma, P. (2020). "Android-Based IoT Device Control Using MQTT Protocol," *Mobile Computing and Applications*, vol. 8, no. 1, pp. 67-75.
- [7] Thompson, R. and Williams, K. (2021). "User Requirements Analysis for Smart Baby Monitoring Systems," *Journal of Consumer Research*, vol. 15, no. 2, pp. 156-168.
- [8] Chen, X., Liu, Y., and Zhou, M. (2018). "Raspberry Pi-Based Childcare Monitoring with Facial Recognition," *Computer Vision Applications*, vol. 22, no. 4, pp. 189-201.
- [9] Kaur, M. and Singh, J. (2020). "Secure Communication Framework for Baby Monitors," *Cybersecurity and Privacy Journal*, vol. 5, no. 3, pp. 234-246.
- [10] Anderson, P., Brown, L., and Davis, C. (2019). "Wearable Sensor Systems for Infant Health Monitoring," *Biomedical Engineering Letters*, vol. 9, no. 2, pp. 145-157.
- [11] Nakamura, T. and Yoshida, H. (2021). "Automated Camera Tracking Algorithms for Monitoring Systems," *Robotics and Automation*, vol. 17, no. 1, pp. 88-96.
- [12] Wilson, E., Taylor, S., and Moore, J. (2018). "Power Management Strategies for Continuous Operation IoT Devices," *Energy Efficient Computing*, vol. 11, no. 4, pp. 267-280.
- [13] Krishnan, V. and Reddy, S. (2021). "Fog Computing Architecture for Baby Monitoring Systems," *Cloud Computing Technologies*, vol. 14, no. 2, pp. 112-124.
- [14] Muller, F. and Schmidt, K. (2019). "Audio Classification for Infant Vocalizations," *Signal Processing Letters*, vol. 26, no. 8, pp. 1145-1152.

- [15] K. M S, R. R. G and S. Karthik, "Streamlining Load Scheduling in Cloud Computing: A Thorough Performance Assessment and Development of Effective Methods for Design," 2024 International Conference on Advances in Modern Age Technologies for Health and Engineering Science (AMATHE), Shivamogga, India, 2024, pp. 1-7, doi: 10.1109/AMATHE61652.2024.10582239.
- [16] Sai Srinivas Vellela, Roja D, NagaMalleswara Rao Purimetla, SyamsundaraRao Thalakola, Lakshma Reddy Vuyyuru, Ramesh Vatambeti, Cyber threat detection in industry 4.0: Leveraging GloVe and self-attention mechanisms in BiLSTM for enhanced intrusion detection, *Computers and Electrical Engineering*, Volume 124, Part A, 2025, 110368, ISSN 00457906, <https://doi.org/10.1016/j.compeleceng.2025.110368>.
- [17] K. N. Rao, B. R. Gandhi, M. V. Rao, S. Javvadi, S. S. Vellela and S. Khader Basha, "Prediction and Classification of Alzheimer's Disease using Machine Learning Techniques in 3D MR Images," 2023 International Conference on Sustainable Computing and Smart Systems (ICSCSS), Coimbatore, India, 2023, pp. 85-90, doi: 10.1109/ICSCSS57650.2023.10169550.
- [18] S. S. Vellela et al., "Improving Medical Image Analysis with Convolutional Neural Networks (Cnns)," 2025 International Conference on Intelligent and Secure Engineering Solutions (CISES), Greater Noida Gautam Budh Nagar, India, 2025, pp. 579-584, doi: 10.1109/CISES66934.2025.11265231.
- [19] S. S. Vellela, L. R. Vuyyuru, K. B. S. K, N. MalleswaraRaoPurimetla, L. Dalavai and M. V. Rao, "A Novel Approach to Optimize Prediction Method for Chronic Kidney Disease with the Help of Machine Learning Algorithm," 2023 6th International Conference on Contemporary Computing and Informatics (IC3I), Gautam Buddha Nagar, India, 2023, pp. 1677-1681, doi: 10.1109/IC3I59117.2023.10397974.
- [20] Kavitha Mettupalayam Subramaniam, Ramachandra Rao Goli, Karthik Subburathinam, Srihari Kannan, Optimization of pyrolysis parameters for enhanced biochar production from agricultural biomass: A study on energy efficiency and carbon sequestration potential, *Science of The Total Environment*, Volume 1015, 2026, 181362, ISSN 00489697, <https://doi.org/10.1016/j.scitotenv.2026.181362>.
- [21]
- [22] K. K. Kumar, S. G. B. Kumar, S. G. R. Rao and S. S. J. Sydulu, "Safe and high secured ranked keyword search over an outsourced cloud data," 2017 International Conference on Inventive Computing and Informatics (ICICI), Coimbatore, India, 2017, pp. 20-25, doi: 10.1109/ICICI.2017.8365348.
- [23] V. Khedkar, N. Vullam, J. R. Babu, U. Bhagyalatha, S. Babu Vadde and A. Lakshmanarao, "Hybrid Classification Approach for Heart Disease using Few Shot Inspired Machine Learning Models," 2025 3rd International Conference on Integrated Circuits and Communication Systems (ICICACS), Raichur, India, 2025, pp. 01-05, doi: 10.1109/ICICACS65178.2025.10968965
- [24] P. Anusha and J. R. Babu, "Enhancing Radiographic Diagnosis: A Novel AI-based Bone Fracture Detection System," 2025 3rd International Conference on Sustainable Computing and Data Communication Systems (ICSCDS), Erode, India, 2025, pp. 1262-1266, doi: 10.1109/ICSCDS65426.2025.11167456.
- [25] R. K. Yarava, G. R. C. Rao, Y. Garapati, G. C. Babu and S. D. V. Prasad, "Analysis on the Development of Cloud Security using Privacy Attribute Data Sharing," 2022 First International Conference on Electrical, Electronics, Information and Communication Technologies (ICEEICT), Trichy, India, 2022, pp. 1-5, doi: 10.1109/ICEEICT53079.2022.9768608.
- [26] K. K. Kommineni and A. Prasad, "A Review on Privacy and Security Improvement Mechanisms in MANETs", *Int J Intell Syst Appl Eng*, vol. 12, no. 2, pp. 90-99, Dec. 2023.
- [27] Kommineni, K.K., Prasad, A. Enhancing Data Security and Privacy in SDN-Enabled MANETs Through Improved Data Aggregation Protection and Secrecy. *Wireless Pers Commun* 139, 855-882 (2024). <https://doi.org/10.1007/s11277-024-11635-w>
- [28] "Blockchain-Enabled Secure Data Aggregation for SDN-Enabled Ad-Hoc Networks," *International Journal of Intelligent Engineering and Systems*, vol. 18, no. 5, pp. 704-717, Jun. 2025, doi: <https://doi.org/10.22266/ijies2025.0630.49>.
- [29] K. K. Kommineni, P. Ande, "Blockchain-driven key management and privacy-preserving data Aggregation Scheme for SDN-enabled MANETs," *International Journal of Intelligent Engineering and Systems*, vol. 18-18, no. 9, pp. 601-615, 2025, doi: 10.22266/ijies2025.1031.39.