



# An Embedded System based Plant Leaf Disease Identification and Classification Using Neural Networks and IoT

T. Krishnaveni, Pichammagari Guru Latha, Degala Swathi, Gangula Nandini, Dibbaguntla Shahini, Gurralla Madhavi

Department of Electronics and Communication Engineering, Gouthami Institute of Technology and Management for Women, Andhra Pradesh, India.

## To Cite this Article

T. Krishnaveni, Pichammagari Guru Latha, Degala Swathi, Gangula Nandini, Dibbaguntla Shahini & Gurralla Madhavi (2026). An Embedded System based Plant Leaf Disease Identification and Classification Using Neural Networks and IoT. International Journal for Modern Trends in Science and Technology, 12(06), 35-41. <https://doi.org/10.5281/zenodo.20573483>

## Article Info

Received: 12 May 2026; Revised: 30 May 2026; Accepted: 02 June 2026.

**Copyright** © The Authors ; This is an open access article distributed under the [Creative Commons Attribution License](#), which permits unrestricted use, distribution, and reproduction in any medium, provided the original work is properly cited.

---

## KEYWORDS

Leaf Disease,  
K-means clustering,  
FCM clustering,  
GLCM features,  
Neural Network, and IOT.

## ABSTRACT

Plant leaf diseases can cause significant reduction in yield. The proposed system is the solution for automatic identification and classification of plant leaf diseases using Artificial neural networks. The dataset contains both infected and non-infected leaf images. The basement of this paper is neural network it will detect the defected region, big particles, clusters and small holes in the leaf. Another important technology used is IoT. The recognition information is transferred with the help of Arduino cable. Based on the plant disease recognition the fertilizer sprays to the field with help of Water motor. The measured parameters are uploaded to Web server through IOT and displayed through LCD Display. By using Temperature and Moisture sensors, we can stop the overflow of water and by high temperature sometimes plants will die so identifying temperature and moisture is the newly added idea. It also includes an Android application which is a user friendly and can be accessed by the farmer that reduces the time consumption and manual working.

---

## 1. INTRODUCTION

Agriculture is that the first livelihood of Indian inhabitants. As of the advent of agriculture, there has been a lot of automatic and biochemical development that has occurred to boost the harvest and facilitate

agriculturalists to test problems like agriculture and crop illnesses. Though there has remained very little to fewer digitization exhausted in this field. With the affluent of IOT, there's a confidence for making an alphanumeric system for agriculture which can facilitate the farmer

create a fair selection regarding his farm and facilitate him tackle some unsought things beforehand. So, it will facilitate to bolster the standard of crops and conjointly, it will be helpful for farmers. Early Recognition of illness which might be a wonderful challenge in cultivation field. AN earlier massive team of specialist's square measure referred to as by the farmers to sketch the diseases or any hurt that occurred to plants, even this apply is not known to all agriculturalist and therefore the specialist's price a lot of and conjointly, it's long. Whereas Instinctive recognition is a lot of helpful than this long method of annotations by the specialists. And thus, Image process technology for early recognition of conditions that happened to plants and may aware agriculturalist at the first stage and save different vegetation from diseases. This study conjointly centered on the blending of sensing element watching techniques with IOT. It has been achieved by interfacing totally dissimilar devices to Arduino board. To avoid severe loss in cultivation wide-ranging Sensors is utilized to measure parameters like soil wetness, temperature, and wetness, chemical and contributes to the production of the farm.

### Proposed System

Proposed associate ANN (Artificial Neural Network) used for the classification of any leaf infested though the diseases. The recital of the system is valid taking place the pictures attained within the material ailment. The proposed system may be an answer used for unconscious recognition and multiplication ff plant's leaves disease. The advanced process theme contains of 5 main steps, initial a color conversion edifice for the effort RGB picture is created, then the noise i.e., needless half is detached exploitation specific beginning price, formerly the images is metameric through allied element labelling and therefore the helpful sections area unit removed, lastly the ANN classification is figured through generous completely dissimilar options i.e., extent, hue, proximity and Average Centroid Distance.

The pictures area unit processed with the assistance of bar chart of compensation that stability the invariableness amongst pictures taken in actual environments.

These pictures area unit re sized to a regular extent picture exploitation the central square crop methodology. Then, the ANN primarily created triple

classification system is accomplished associated verified for the recognition of the any leaf contaminated in view of succeeding key facts: Through instinctive and an initial diagnosing of a sickness and its brutality, operative, and appropriate action may be occupied in advanced. This may conjointly support in distinctive the seasons and fertilizers to be used for the sickness, therefore serving to be told vulnerability among them. Artificial neural networks (ANN) take input as associate unstructured image apply procedure model that works on and renovates them into equivalent organization production labels. It needs fewer preprocessing efforts which may be accomplished to be stated the specified options aimed at arrangement purposes.

For this exertion, actual situations well and infected leaf pictures area unit collected for the any plant affected by sickness. More, the efficiency of the system is valid taking place the composed and customary information base when put next by the opposite progressive approaches. The projected methodology is automatic, computationally economical, and efficient, which will facilitate in supporting the reputation of the any plant and it's crops each environmentally and cautiously {the pictures} area unit preprocessed by the assistance of bar chart of compensation that equilibrium the invariableness amongst descriptions taken in actual environments. Then, the ANN primarily created triple arrangement system is accomplished and verified for the recognition of the leaf's sickness in step with the seasons and plant food used for.

### Method of Back Propagation

The texture options can performance as inputs to a Neural Network and also the diseases are going to be situated targeted. Specified an input, that establishes the 9 consistency options, the Neural Network is anticipated to spot correct disease. This can be achieved by presenting antecedently verified inputs to a Neural Network and so standardization it to supply the required target outputs. This method is termed Neural Network coaching algorithmic rule used for sorting in ANN. Formulating the information, the texture options similar distinction, correlation, homogeneity, energy, entropy, mean, kurtosis, imbalance and variance square measure extracted by exploitation GLCM and initial order applied mathematics moments technique. And also, the values of options square measure keep in CSV files. The primary 9

columns of data provide 9 texture options and one-tenth columns provides the category. The categories for ex. Unhealthy and Well will remain diagrammatic as [0 1] and [1 0] severally.

### 1.2 Working flow of proposed system

First give the infected leaf images as input image in the figure 1. These are the 4 steps included in the Working flow of proposed approach.

- Preprocessing
- Segmentation
- Feature extraction
- Classification

#### 1.2.1 IMAGE PROCESSING

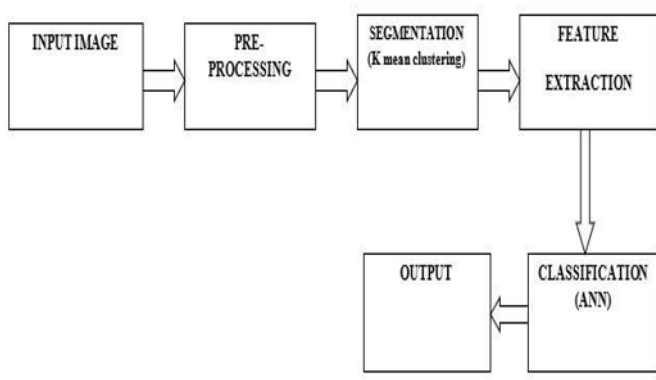

Fig -1: Image Processing

#### 1.2.2 INPUT IMAGE

First, give the infected leaf image as an input image is shown in below figure 2. not which we tend to reborn in to a few categories RGB once dividing we'll check whether or not or not it's 256\*256 image or not and convert it into a gray scale image then covert that image in to red bar graph, inexperienced bar graph and blue bar graph then combine all bands in to a minimum of one bar graph then masking square measure finished the chosen color pictures.

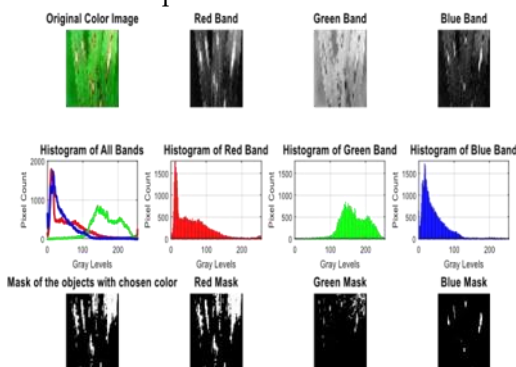

Fig-3: Pre processing

#### 1.2.4 SEGMENTATION

Fig-2: Input Image clustering based method is applied in this process. As Enhanced K-mean clustering algorithm is used to examine the infested part of a leaves. Then we have to section the image in to K different regions then FCM

#### 1.2.3 PRE-PROCESSING

Reading the image that technique is termed preprocessing. The photographs that square measure obtained throughout image acquisition may not be applicable straight for identification and classification functions owing to sure factors, like noise, lighting variations, climate, poor resolutions of associate photos, unwanted background etc. As a result of the photographs are noninheritable from the field it's attending to contain dirt, bacteria and spots as blast. The aim of information preprocessing is to eradicate the blast among the picture, so on alters the component ideals. So, it augments the excellence of a picture. Initial take associate input image divided into row, column, color band then dynamic to 256\*256. Then we have got to examine whether it is a unit eight image or shown in the figure 3. The object masking will be done for only big particles, filled holes, erosion, and for boundary of detected region.

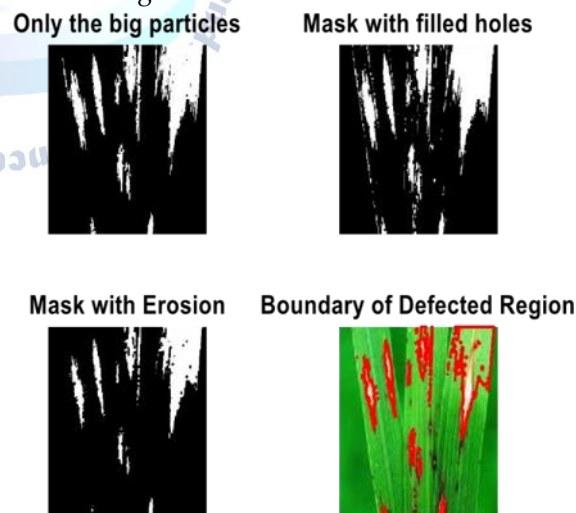

Fig-3: Segmentation

#### FCM (Fuzzy C Means Clustering)

As shown in the figure 4. fuzzy c-means (FCM) formula may be a bunch formula advanced through Dunn, and well along enhanced by Bezdek. It's beneficial once the essential vary of collections area unit pre-determined thus, the formula attempts to set to each of the

information point to a minimum of one in all the cluster. That make FCM altogether completely dissimilar is that it ensures not resolve completely the membership of AN data purpose to a given cluster; instead, it calculates the data purpose resolve be in the right place to that clustering. Henceforth, looking on the accurateness of the bunch that is essential in follow, applicable acceptance measures in a place. Meanwhile completely the involvement is not intended, FCM is also terribly debauched as a result of the number of repetitions vital to achieve a particular bunch exercise corresponds to the required accuracy.

FCM Cluster Index No: 1

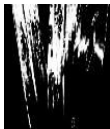

FCM Cluster Index No: 2



FCM Cluster Index No: 3



FCM Cluster Index No: 4



FCM Cluster Index No: 5



FCM Cluster Index No: 6



Fig-4: FCM clustering

### 1.2.5 FEATURE EXTRACTION

In feature extraction DWT (Discrete Wavelet Transform) operation will be done using these GLCM for getting the clear image is shown in the figure 5.

GLCM The Gray level co-occurrence matrix may be a math approach it's used to calculate the texture choices. This system may be a way of extracting ensuant order math texture choices. The conditions of matrix represent the frequency.

These area unit variety of the properties of GLCM.

1. Generate a grey level co-occurrence matrix. With a matrix of size  $N \times N$  where  $N$  is that the vary of Stages in such below division.

2. Component distinction instant of order  $k$ :  $P_i P_j (i-j) k_{ij}$ . This descriptor takes comparatively little standards once the high standards area unit on the brink of the foremost oblique. Used for these situation operative, high

standards on the brink of the foremost transverse will specify that groups of persistent concentration consecutively "1 element to the proper and one down" area unit on the face of its  $k = a$  combine of, it's referred to as the excellence.

$$Energy = \sum_{i,j=0}^{N-1} (P_{ij})^2$$

$$Entropy = \sum_{i,j=0}^{N-1} -\ln(P_{ij}) P_{ij}$$

$$Contrast = \sum_{i,j=0}^{N-1} P_{ij} (i-j)^2$$

$$Homogeneity = \sum_{i,j=0}^{N-1} \frac{P_{ij}}{1+(i-j)^2}$$

$$Correlation = \sum_{i,j=0}^{N-1} P_{ij} \frac{(i-\mu)(j-\mu)}{\sigma^2}$$

$$Shade = \text{sgn}(A) |A|^{1/3}$$

$P_{ij}$  = Elements  $ij$  is that the standardized proportioned GLCM.  $N$  = range of gray echelons inside the picture intrinsically through variety of stages in below division of a GLCM texture of the Inconstant properties panel.

$\sigma$  = The modification of the concentrations of entirely orientation picture element inside the relations that underwritten to the GLCM, is intended as:

$$\sigma^2 = \sum_{i,j=0}^{N-1} P_{ij} (i-\mu)^2$$

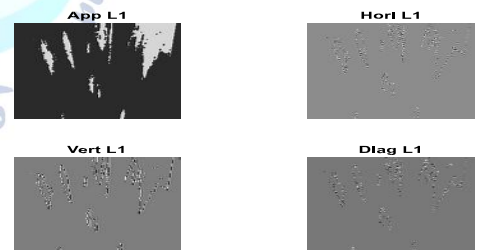

Fig-5: FCM clustering

### 1.2.6 CLASSIFICATION USING NEURAL NETWORKS

Neural Networks (NN) area unit vital data processing hidden layer tools that is used for classification and clustering. It's a project to create a mechanism that can replicate brain purposes and learns it. In most cases, neural networks learn from instances. If NN is given enough samples, it should be able to perform categorization and perhaps uncover new knowledge forms. In a basic NN, there are three layers: input, output, and hidden layer Every element will also have a different node, with nodes from the input layer connecting to node from its hidden layer. Nodes as of the

area unit of the hidden network is allied to node from the output layer. Weights between nodes are represented by those connections. Artificial neural networks (ANN) consider categorization in conjunction with the most inherent dynamic research and different applications. The main drawback of utilizing ANN is locating the most appropriate grouping of training, learn, and transferring function for categorizing sets of data with an ever-increasing variety of possibilities and classed sets.

The impact of various combinations of operations when using an ANN as a classifier is investigated, as well as the accuracy of such algorithms is assessed for several real datasets. The backpropagation networking is by far the most also includes water motor. The data regarding moisture and temperature of a particular successful technology used in the database classifications. The Back-Propagation Network (BPNN) was used to classify the images in the neural net. To optimize the neural network parameters, the error resulting from the disparity between both the output layer and the purpose is used. Once the model has been training, it will produce an output for hidden information. FFNNs are a type of multi-layer neural network that allows signals to go from input to output in a single direction. This system must be given training on such a set of data.

The weight of the neural connections then is fixed, and the system is subsequently used to determine the classification of a product given set of data. During categorization, the signals from the input layer travels all the way across the internet to calculate the activation levels in the smallest output nodes. Each input unit has to have an activating value that indicates how much it costs to use it. Subsequently, with each hidden neuron with which it is attached, every input unit communicates its activating price. Each of the hidden neurons determines on its activating price, which is subsequently passed that onto the output nodes. Each received unit's activating price is derived using a simplified deep analytical.

Each work amounts every causality unit' contribution, with a unit's contributions defined as that of the weight of both the connection between the causality and reception units multiplied by the causation unit's activation price. One such amount can sometimes be so any modified, for this, through changing the activating complete among zero and then one and/or through

reducing an activating target value until an image quality for the that entire is achieved.

## 2. System Model and Implementation

The hardware part shown in the figure 6 includes Arduino board, power supply like transformer, sensors like soil moisture, humidity and temperature (DHT11). It collected from the sensors. The sensed data is then transmitted to Arduino for furthprocessing through patcables. The Arduino is designed using c programming for data processing and the processed digital data is carried out through a serial com port for simulation. The measured Water motor.

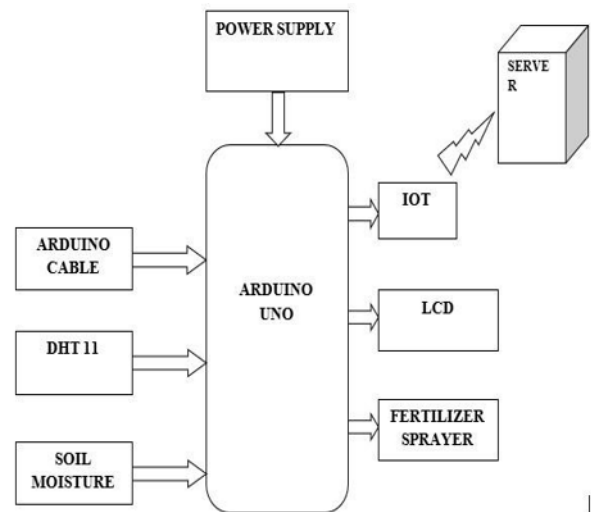

Fig-6: Hardware Block

## 3. RESULTS AND DISCUSSION

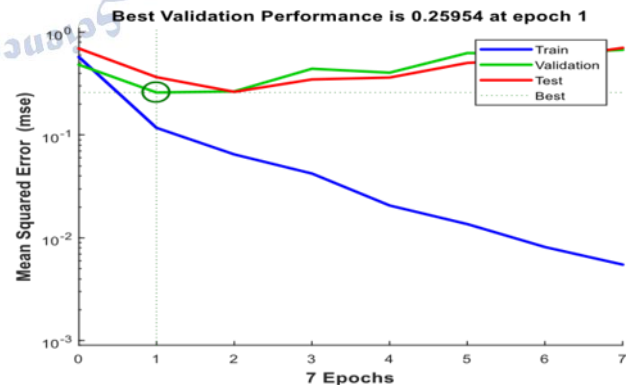

Fig -7: Performance graph

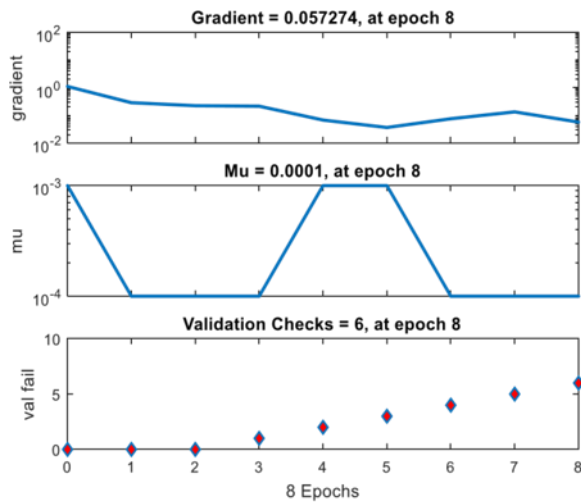

Fig-8: Training State

parameters are uploaded to Web server through IOT and displayed through LCD Display. If it detects plant disease fertilizer sprays to the field with help of

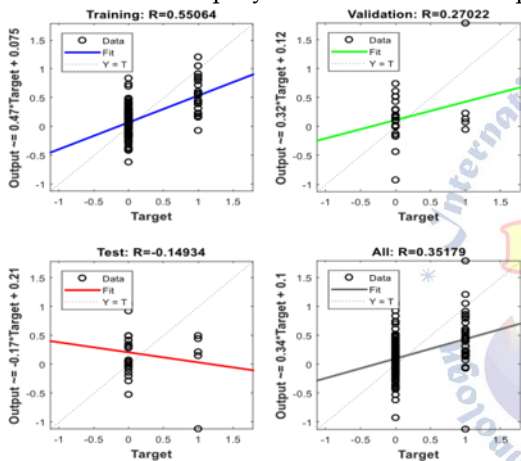

Fig-9: Regression

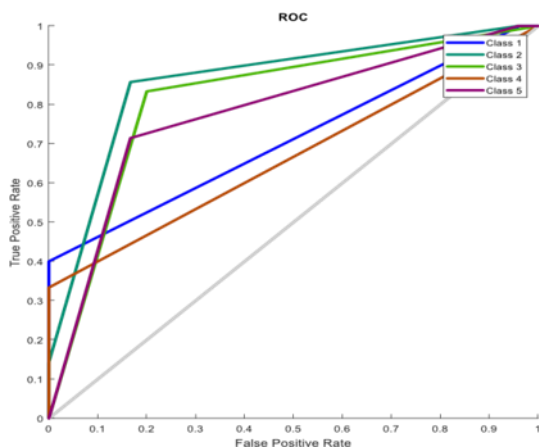

Fig-10: Receiver operating characteristic graph

#### 4. CONCLUSIONS

Main objective is to surge the usefulness and application of research outcomes in agriculture. By strengthening

the scope of research activities and utilization of research and intellectual property in the most effective way, thereby increase effectiveness. The proposed result is for automatic identification and classification of plant leaf disease using neural networks. This project includes temperature sensor, moisture sensor, and fertilizer sprayer if plant is infected by a disease automatically fertilizer spray will on and temperature sensor worn for sensing temperature in soil and moisture sensor is worn to sense the moisture in the soil so we can give sufficient water to plant. By using these sensors, we can stop the overflow of water and by high temperature sometimes plants will die so identifying temperature and moisture content is useful. The recognition of the plant diseases information is transferred with the help of Arduino cable. Based on the plant disease recognition the fertilizer sprays to the field with help of Water motor. In future adding more sensors like remote sensing for environmental monitoring, it provides information on ecosystem, and drought mitigation temperature sensor, moisture sensor, and fertilizer sprayer if plant is infected by a disease automatically fertilizer spray will on and temperature sensor worn for sensing temperature in soil and moisture sensor is worn to sense the moisture in the soil so we can give sufficient water to plant. By using these sensors, we can stop the overflow of water and by high temperature sometimes plants will die so identifying temperature and moisture content is useful. The recognition of the plant diseases information is transferred with the help of Arduino cable. Based on the plant disease recognition the fertilizer sprays to the field with help of Water motor.

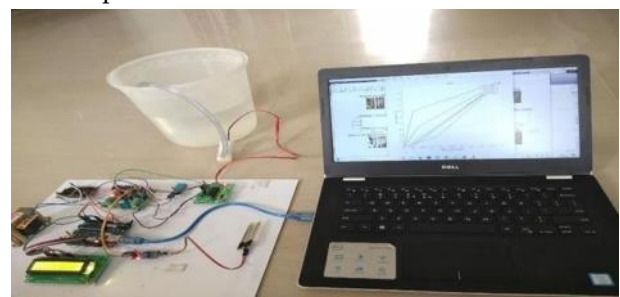

Fig-11: Hardware Connection to Arduino Cable

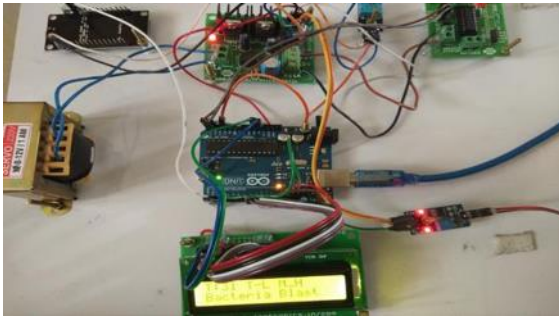

Fig-12: Hardware Part

### Conflict of interest statement

Authors declare that they do not have any conflict of interest.

### REFERENCES

- [1] Mohammed Hussein, Amel h. Abbas, "Plant leaf disease detection using support vector machine". August 2019.
- [2] N. Kanaka Durga, G. Anuradha, "Plant disease identification using SVM and ANN algorithm".
- [3] M. Ravindra Naik, Chandra mohan reddy sivappagiri, "Plant disease detection by using HSV features and SVM classifier" IJESC 2016.
- [4] Mulham Fawakherji, Ali Youssef, Domenico D. Bloisi, Alberto Pretto and Daniele Nardi "Crop and Weeds Classification for Precision Agriculture using ContextIndependent Pixel-Wise Segmentation".2018
- [5] Kapilya Gangadharan, G. Rosline Nesa Kumari, D. Dhanasekaran. "Classification and Functional Analysis
- [6] Yun Zhang, Dongjian He and Yuxiang Li. "Identification of Apple Leaf Diseases Based on Deep Convolutional Neural Networks"2018.
- [7] Philippe A. Dias, Amy Tabb, and Henry Medeiros," Multispecies fruit flower detection using a reined semantic segmentation network".2018
- [8] Jyoti Shirahatti, Rutuja Patil, Pooja Akulwar, "A Survey Paper on Plant Disease Identification Using Machine Learning Approach" ICCES 2018.