



# Multifunctional Army Robot

**B Mallikarjuna Reddy, Ulasala Chandra Lekha, Ketha Lavanya, Lekkala Swetha, Chowdam Sravani, Bushireddy Siva Maheshwari**

*Department of Electronics and Communication Engineering, Gouthami Institute of Technology and Management for Women, Andhra Pradesh, India.*

## To Cite this Article

B Mallikarjuna Reddy, Ulasala Chandra Lekha, Ketha Lavanya, Lekkala Swetha, Chowdam Sravani & Bushireddy Siva Maheshwari (2026). Multifunctional Army Robot. International Journal for Modern Trends in Science and Technology, 12(05), 312-316. <https://doi.org/10.5281/zenodo.20363846>

## Article Info

Received: 25 April 2026; Revised: 19 May 2026; Accepted: 23 May 2026.

**Copyright** © The Authors ; This is an open access article distributed under the [Creative Commons Attribution License](#), which permits unrestricted use, distribution, and reproduction in any medium, provided the original work is properly cited.

---

### KEYWORDS

PIR Sensor, Ultrasonic Sensor, ESP32-CAM.

### ABSTRACT

Science is a field developing in a rapid phase in order to create the technology which can make human life easier. Nowadays, many innovations and inventions are made in the field of defence to reduce the loss of human lives. One such invention is Multi-functional Army Robot that plays a vital role in reducing the damages that occur during disasters. The main objective is to implement a multifunctional army robot consisting of various sensors. The proposed system consists of a wireless camera for live video streaming surveillance, PIR sensor for human detection and Metal detector for detecting land mines and Ultrasonic sensor for obstacle detection. In the proposed model the mobile connects with the Bluetooth and ESP32-CAM. This project has proposed the system using the Arduino, metal detectors, PIR sensor, Ultrasonic sensor and laser sensor which help the robot to do multi functionalities to do rescue operations.

---

## 1. INTRODUCTION

Robots are mechanical devices, that are capable of performing the difficult and complex tasks on their own and also based on the commands. As the technology was booming in the present era, it is safe to use robots rather than the human for performing particular tasks and robots can do more difficult tasks and it can be moved to places, where human cannot go and complete the tasks in a more efficient way.

Defence system is a major asset to any country in this world. Safeguarding the country against the enemies is one of the prioritised things to keep the country's

economy, assets, valuable treasures and lives of the people in a safest way. In the defence the most required and the new equipment's are the military robots. Nowadays, military robots are considered to be the future of modern warfare. At the same time, military robotics is considered to be the game-changing technology that could change the structure and employment of armed forces. Society is aware of the military employment of robots today. These military robots are of various types for the uses like transportation, attacking enemies, disaster management and civil supplies. The proposed model utilises different

sensors like PIR sensor, Ultrasonic sensor, and metal detectors for performing different operations. The technology has grown in such a way that the robots can be operated wirelessly and can be operated in remote areas, human loss can be minimised in the defence which leads to less human loss. Using the Multi-functional army robot, we can able to build a robot which can act as spy.

## 2. RELATED WORK

### 1. Existing System:

There are so many types of military spying robots available. Every model has its own features and operations. ESP32-CAM is main functionality system of entire project along with Arduino. It can stream video through WIFI network. DC gear motors controlled by L293d which are connected to Arduino digital pins. Also, it will rotate in vertical direction with DC gear motor. It can be operated using a WIFI module. It is the interface between the user and the system.

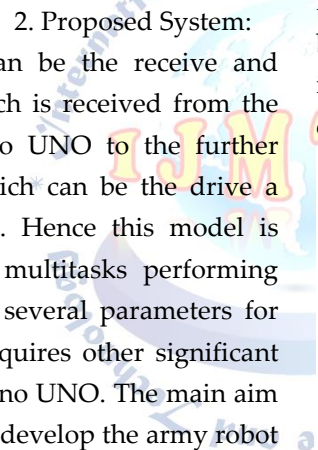

**2. Proposed System:**  
 We created a system which can be the receive and implement the information which is received from the smart phone using the Arduino UNO to the further control of the motor drives which can be the drive a robot in the required direction. Hence this model is design for the making of the multitasks performing along with the checking to the several parameters for system monitoring for this it requires other significant tasks on its own using the Arduino UNO. The main aim of this model is to be design and develop the army robot and it is operated by a smart phone. The proposed model consist a spy camera to capture the real time data as video. It consist of PIR sensor for detecting humans and also metal detector to detect landmines. The proposed model consist of a Bluetooth module for sending and receiving data. It also consist a laser sensor for obstacle detection. The proposed model sends a beep sound when it detects a human od a metal or an obstacle. The user operates the proposed model by using Arduino Bluetooth controller application. This model helps to substitute the human loss in military.

### Block Diagram:

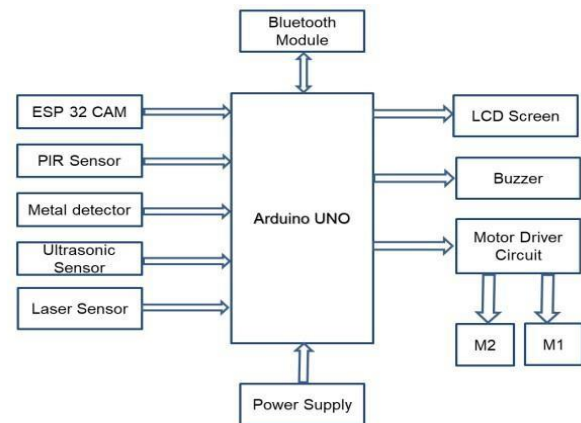

Fig: Block diagram of proposed system

## 3. COMPONENTS:

### Arduino UNO:

The Arduino Uno is an open-source microcontroller board based on the Microchip ATmega328P microcontroller and developed by Arduino UNO. The board is equipped with sets of digital and analog input/output pins that may be interfaced to various expansion boards and other circuits.



Fig 3.1: Arduino UNO

### Bluetooth Module:

Bluetooth module uses serial communication to communicate with electronics. It is used to connect small devices like mobile phones using a short-range wireless connection to exchange files. It uses the 2.45GHz frequency band.



Fig 3.2: Bluetooth Module

PIR Sensor:

Passive Infrared Sensors use a pair of pyroelectric sensors to detect heat energy in the surrounding environment. It works on the principle that change infrared radiation; it generates a digital output signal.



Fig 3.3: PIR Sensor Metal Detector: \*

A metal detector is an instrument that detects the nearby presence of metal. Metal detectors consist of a coil that transfers electromagnetic field into ground. If any metal or landmines are present within the field then the EMF gets activated and sends back the signal.



Fig 3.4: Metal detector

Laser Sensor:

When the laser pen shines on the photoresistor then the system is in safe mode. If any obstacle passes between the laser and LDR receiver then it shows the obstacle detection and gives an alert. In this project LDR acts as a receiver.

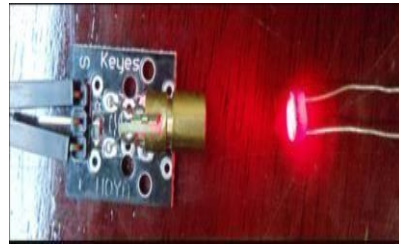

Fig 3.5: Laser Sensor

LCD:

A liquid-crystal display (LCD) is a flat-panel display or other electronically modulated optical device that uses the light-modulating properties of liquid crystals combined with polarizers. Liquid crystals do not emit light directly but instead use a backlight or reflector to produce images in color or monochrome.

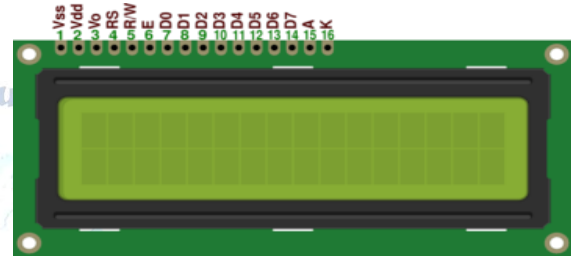

Fig 3.6: LCD

ESP 32 cam:

The ESP32-CAM is a small size, low power consumption camera module based on ESP32. It comes with an OV2640 camera. It can provide a real-time visual data to the robot's control system for object recognition.



Fig 3.7: ESP 32 cam

L293D MOTOR DRIVER:

L293D motor driver is mounted on a good quality, single-sided non-PTH PCB. The pins of L293D motor driver IC are connected to connectors for easy access to the driver IC's pin functions. The L293D is a Dual Full

Bridge driver that can drive up to 1Amp per bridge with supply voltage up to 24V. It can drive two DC motors.

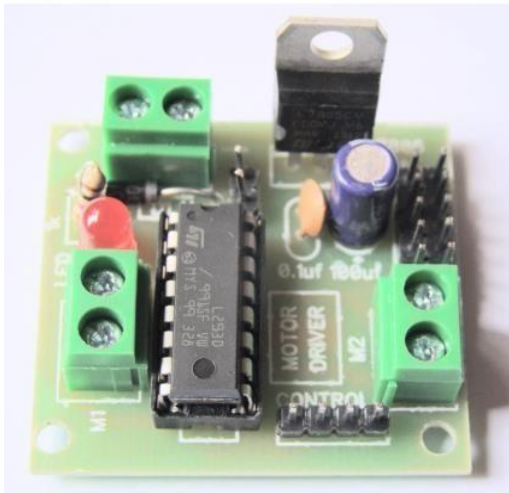

Fig 3.8: L293D Motor Driver

DC Motor:

A DC motor is any of a class of electrical machines that converts direct current electrical power into mechanical power. Nearly all types of DC motors have some internal mechanism to periodically change the direction of current flow in part of the motor.



Fig 3.9: DC Motor

Arduino IDE:

Arduino IDE is an open-source software, designed by Arduino.cc and mainly used for writing, compiling & uploading code to almost all Arduino Modules. It is an official Arduino software, making code compilation too easy that even a common person with no prior technical knowledge can get their feet wet with the learning process.

Arduino Bluetooth Controller:

This app allows you to remotely control any device with an Arduino board and HC-05 Bluetooth module.

#### 4. RESULT

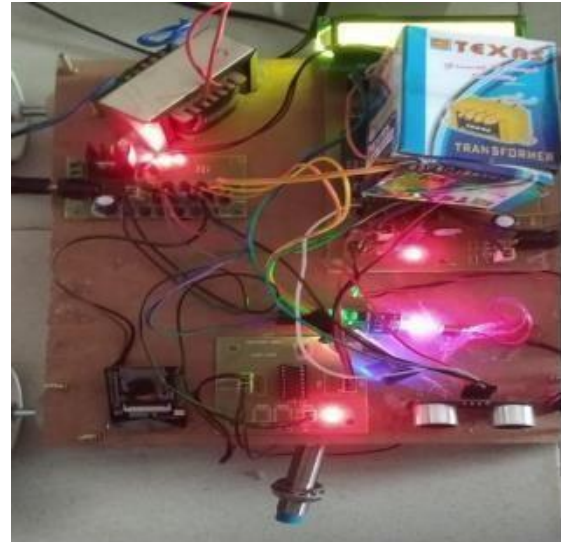

Fig 4.1: Multifunctional Army Robot



Fig 4.2: Living beings detected by PIR Sensor



Fig 4.3: Object detected by Ultra Sonic Sensor

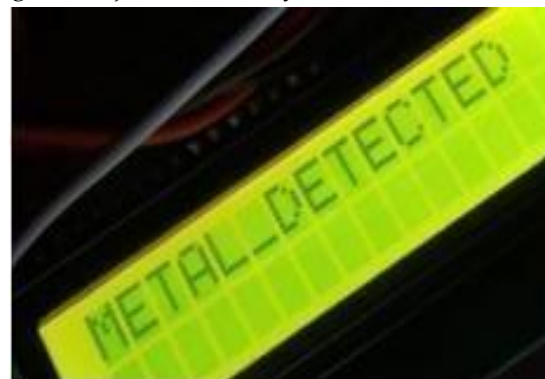

Fig 4.4: Metal detected by Metal Detector



Fig 4.5: Live video from ESP32-CAM

HC-05: distance65.76cm OBJECT\_DETECT  
 HC-05: PIR\_ACTIVATED  
 HC-05: METAL\_DETECTED  
 HC-05: distance801.51cm OBJECT\_DETECT  
 HC-05: SAFE  
 HC-05: distance68.75cm OBJECT\_DETECT  
 HC-05: SOMEONE\_CROSS\_THE\_LASER  
 HC-05: SAFE  
 HC-05: distance801.60cm OBJECT\_DETECT

Fig 4.6: Detected values display in Mobile Phone

## 5. CONCLUSION

We are concluding the paper that Multifunctional Army Robot can send a live video through ESP 32 cam and it can able to detect metals, living beings by using Metal detector and PIR sensor. This Robot avoid obstacles by using ultrasonic sensor. The data which is collected by the robot is sent to nearby operator through Bluetooth module.

### Conflict of interest statement

Authors declare that they do not have any conflict of interest.

### REFERENCES

- [1] Balaji. M, Karthick.S, Manikandan.V, Benedict Ebinesar.J, Vijay Nagaraj "Surveillance and Target Engagement using Robots" IOSR Journal of Electronics and Communication Engineering 2017, pp.01-06.
- [2] Tarun Preet Kaur, Dilip Kumar, "Wireless Multi-functional Robot for Military Applications" Proceedings of 2015 RAEC SUIET Panjab University Chandigarh 21-22nd December 2015: 978-14673-82533/15©2015 IEEE.

- [3] Pooventhana K, Achuthaperumal R, Kowshik S3 Manoj Balajee C "Surveillance Robot Using Multi Sensor Network". International journal of innovative research in electrical, electronics, instrumentation and control engineering Vol. 3, Issue 2, February 2015 ISSN (Online) 2321- 2004 4. Kunal Borker1, Rohan Gaikwad2,
- [4] Ajay Singh Rajput3, "Wireless Controlled Surveillance Robot" International Journal of Advance Research in Computer Science and Management Studies. ISSN: 2321-7782,Volume.2,Issue.2,February2 014.
- [5] Dr. Shantanu K. Dixit, "Design and Implementation of e-surveillance Robot for Video Monitoring and Living Body Detection", International Journal of Scientific and Research Publication, Volume 4, issue 4, April 2014, ISSN2250-3153
- [6] Premkumar. M "Unmanned MultiFunctional Robot Using Zigbee Adopter Network for Defense Application" International Journal of Advanced Research in Computer Engineering & Technology (IJARCET) Volume 2, Issue 1, January2013.

