



IOT based smart vehicle parking system

Dr. L. Ravi Srinivas, Goriparthi Kavya, Medepalli Madhava Rao, Gudapati Karthik, Chandaka Naresh, Bethapudi Gowtham.

Department of Electrical and Electronics Engineering, Gudlavalleru Engineering College, Andhra Pradesh, India.

To Cite this Article

Dr. L. Ravi Srinivas, Goriparthi Kavya, Medepalli Madhava Rao, Gudapati Karthik, Chandaka Naresh & Bethapudi Gowtham. (2026). IOT based smart vehicle parking system. International Journal for Modern Trends in Science and Technology, 12(04), 829-836. <https://doi.org/10.5281/zenodo.19637684>

Article Info

Received: 17 March 2026; Revised: 12 April 2026; Accepted: 15 April 2026.

Copyright © The Authors ; This is an open access article distributed under the [Creative Commons Attribution License](#), which permits unrestricted use, distribution, and reproduction in any medium, provided the original work is properly cited.

KEYWORDS	ABSTRACT
IoT-based parking system, ESP32 microcontroller, IR sensor vehicle detection, real-time slot monitoring, smart city parking management, automated gate control, cloud-based parking application	With the rapid pace of urbanization and the exponential growth in the number of vehicles, efficient parking management has emerged as a critical challenge in modern smart cities. Conventional parking systems are largely manual, inefficient, and contribute significantly to traffic congestion, fuel wastage, and driver frustration. This paper presents the design and implementation of an IoT-Based Smart Car Parking System that enables real-time detection, monitoring, and management of parking slot availability. The proposed system integrates infrared (IR) sensors for vehicle presence detection, an ESP32 microcontroller for data acquisition and wireless communication, micro servo motors for automated gate control, and a 16x2 LCD with I2C interface for on-site slot status display. Detected parking data is transmitted over Wi-Fi to a cloud server, which feeds a web-based application accessible to users in real time. The web interface, deployed at a publicly accessible URL, provides live updates on available and occupied parking slots, enabling drivers to identify and navigate to the nearest vacant space before arrival. The system also supports automated slot allocation and reservation features, further enhancing operational efficiency. Experimental results demonstrate that the system accurately detects vehicle occupancy, updates slot status with minimal latency, controls entry and exit gates autonomously, and presents real-time information seamlessly on both the LCD and the web platform. The proposed solution achieves significant improvements in space utilization, reduction in traffic congestion, and overall user convenience. The work validates the effectiveness of IoT integration in everyday urban infrastructure and offers a scalable, cost-effective framework applicable to parking facilities of varying sizes in smart city environments.

1. INTRODUCTION

The rapid pace of urbanization witnessed over the past few decades has led to an unprecedented increase in the number of registered vehicles in cities worldwide. As urban populations continue to grow, the demand for adequate parking infrastructure has far outpaced the available supply, giving rise to a host of problems including prolonged search times, unnecessary fuel consumption, and significant traffic congestion in city centers [5]. Studies have consistently shown that a considerable proportion of urban traffic is generated by drivers circling in search of available parking spaces, contributing to both environmental degradation and reduced quality of life for city inhabitants [6]. In this context, the development of intelligent, technology-driven parking management solutions has emerged as a critical priority for smart city initiatives globally.

Traditional parking systems rely predominantly on static signage or manual supervision, which are inherently incapable of providing real-time information about slot availability. Such systems are inefficient, labor-intensive, and poorly suited to the dynamic nature of modern urban traffic [1]. The absence of real-time data means that drivers cannot make informed decisions before entering a parking area, resulting in wasted time and avoidable congestion. These limitations have motivated researchers and engineers to explore automated, sensor-driven parking solutions that leverage the Internet of Things (IoT) paradigm to deliver timely and accurate information to end users [2,3].

IoT-based smart parking systems address these challenges by deploying sensor networks at individual parking slots to detect vehicle presence and transmitting this data in real time to centralized cloud platforms, which in turn make the information accessible to users through mobile or web-based applications [2]. The integration of low-cost sensors, energy-efficient microcontrollers, and ubiquitous wireless connectivity has made such systems increasingly feasible for large-scale urban deployment [4]. Furthermore, the inclusion of automated physical control elements, such as servo motor-driven entry and exit gates, enhances security and enforces orderly access to parking facilities [7].

Motivated by these considerations, this paper presents the design and implementation of an IoT-Based Smart Car Parking System that integrates infrared (IR) sensors for real-time slot occupancy detection, an ESP32 microcontroller for local processing and wireless data transmission, servo motors for automated gate control, a 16x2 LCD with I2C interface for on-site display of available slot counts, and a cloud-connected web application that allows users to remotely monitor parking availability. The proposed system demonstrates how affordable, off-the-shelf components can be combined into a cohesive and scalable smart parking solution suitable for real-world urban environments [3,7].

The key contributions of this work are as follows: (i) a fully integrated hardware-software architecture for automated parking slot detection and gate control; (ii) real-time cloud synchronization enabling remote monitoring through a publicly accessible web interface; (iii) demonstration of ESP32-based IoT deployment for smart city parking applications; and (iv) validation of the system through a functional prototype that confirms reliable sensor detection, accurate slot status reporting, and responsive gate actuation.

The remainder of this paper is organized as follows. Section 2 reviews related work in IoT-based parking systems. Section 3 describes the proposed system architecture and hardware components. Section 4 details the software design and web application interface. Section 5 presents the experimental results and performance evaluation. Finally, Section 6 concludes the paper and outlines directions for future work.

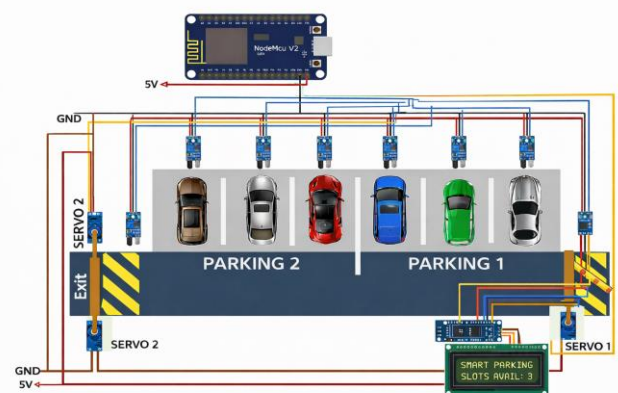

Figure 1: Overview of the proposed system and research scope

2. LITERATURE REVIEW

The rapid proliferation of vehicles in urban environments has intensified the demand for intelligent parking management solutions. Over the past decade, a substantial body of research has explored various IoT-enabled and sensor-based approaches to address the inefficiencies inherent in conventional parking systems. This section reviews the most relevant prior works, highlights their contributions and limitations, and identifies the research gaps that motivate the present study.

One of the earliest and most frequently cited contributions in this domain is the work by Khanna and Anand [1], who proposed an IoT-based smart parking framework leveraging sensor networks and wireless communication to monitor slot occupancy in real time. Their system demonstrated the feasibility of automating parking detection, yet it lacked a scalable cloud backend and offered no user-facing mobile or web interface, limiting its practical deployment in large-scale urban settings. Building upon such foundational concepts, Pham et al. [2] introduced a cloud-based smart parking architecture that integrated IoT technologies with remote data processing, enabling users to query slot availability via networked applications. While this work significantly advanced the cloud integration aspect, the system's reliance on proprietary hardware and the absence of cost-effective microcontroller platforms constrained its widespread adoption.

The role of the Internet of Things in broader smart city infrastructure was comprehensively examined by Zanella et al. [5], who outlined communication protocols, sensor deployment strategies, and data management frameworks applicable to urban services including transportation and parking. Their survey established a theoretical foundation for IoT-driven urban solutions but did not address the specific challenges of real-time automated gate control or user-guided slot reservation. A more focused survey by Lin et al. [6] systematically classified smart parking solutions across dimensions such as sensing technology, communication architecture, and user interaction modalities. The authors identified that most existing systems excel in detection accuracy but fall short in providing end-to-end automation, particularly in integrating physical actuation mechanisms—such as barrier gates—with digital monitoring platforms.

More recent implementations have sought to bridge this gap. Suresh et al. [3,4] developed a smart parking system employing IR sensors interfaced with IoT platforms to detect vehicle presence and relay occupancy data to cloud servers, demonstrating improved response times and reduced false-positive rates compared to ultrasonic-based alternatives. However, their prototype did not incorporate automated gate control or a publicly accessible web dashboard, leaving the user interaction layer underdeveloped. Abutaleb and El-Wakeel [3] specifically utilized the ESP32 microcontroller for real-time IoT-enabled parking management, highlighting the module's dual-core processing capability and native Wi-Fi support as key enablers for low-latency cloud communication. Despite these strengths, the system lacked an onsite display mechanism to inform drivers without smartphone access. Verma and Gupta [7] addressed physical actuation by integrating servo motors and an LCD display within a microcontroller-based IoT platform for automated slot allocation, yet their solution was evaluated only in a controlled laboratory environment without deployment on a live web application.

Collectively, the reviewed literature reveals several persistent gaps: (i) most systems address either detection or actuation in isolation, rarely combining both within a unified architecture; (ii) onsite informational displays are frequently omitted, reducing accessibility for non-smartphone users; (iii) few prototypes couple physical gate automation with a real-time, publicly hosted web interface; and (iv) scalability and cost-effectiveness remain underexplored in the context of emerging economies. The present work directly addresses these gaps by integrating IR-sensor-based detection, ESP32 cloud connectivity, servo-motor-driven gate control, an I2C LCD onsite display, and a live web-based user interface into a cohesive, low-cost smart parking system.

3. SYSTEM ARCHITECTURE

The proposed IoT-Based Smart Car Parking System is designed around a layered, modular architecture that seamlessly integrates physical sensing hardware, embedded processing, cloud-based data management, and a web-based user interface. The overarching design philosophy prioritizes real-time responsiveness, scalability, and ease of deployment, reflecting principles

widely advocated in IoT-driven smart city frameworks [5]. By decoupling sensing, processing, communication, and presentation into distinct functional layers, the system achieves both flexibility and maintainability, allowing individual modules to be upgraded or scaled independently without disrupting overall operation [6].

At the lowest layer resides the perception tier, comprising infrared (IR) sensors strategically positioned at each parking slot. These sensors continuously emit infrared radiation and monitor reflected signals to determine slot occupancy. When a vehicle occupies a slot, the reflected IR signal triggers a HIGH output, which is relayed to the central microcontroller [4]. The simplicity and reliability of IR-based detection make it a cost-effective choice for embedded parking applications, as confirmed by prior implementations in urban traffic management contexts [4].

The processing tier is anchored by the ESP32 microcontroller, which serves as the system's computational and communication hub. The ESP32 continuously polls the IR sensors, interprets occupancy states, drives the servo motor gate mechanism, updates the 16x2 I2C LCD display with real-time slot counts, and transmits aggregated parking data to the cloud server via its onboard Wi-Fi module [3]. The selection of the ESP32 was deliberate; its dual-core processing capability, integrated Wi-Fi and Bluetooth support, and low power consumption make it particularly well-suited for IoT edge applications requiring simultaneous local control and remote connectivity [1,3]. The microcontroller executes a PWM signal to command the micro servo motor, which physically opens or closes the parking gate based on vehicle detection at the entry point, thereby automating access control [7].

The communication tier leverages the ESP32's Wi-Fi capability to transmit real-time parking status data to a cloud-hosted backend. This cloud integration enables persistent data storage, state synchronization across multiple clients, and remote accessibility—capabilities essential for any scalable smart parking deployment [2]. The adoption of cloud-based platforms for IoT parking systems has been demonstrated to significantly improve data availability and system responsiveness compared to purely local processing approaches [2,3].

The presentation tier consists of a web application hosted at a publicly accessible URL, developed to provide users with an intuitive interface for monitoring

slot availability in real time. The application displays current occupancy status, distinguishing between available and occupied slots, and is designed for accessibility across both desktop and mobile browsers. This approach aligns with the user-centric design principles outlined in cloud-based smart parking literature [2,6].

A key design trade-off involved balancing system complexity against reliability. While camera-based or ultrasonic sensing could offer greater accuracy, IR sensors were selected for their simplicity, low cost, and sufficient precision for slot-level detection [4]. Similarly, the I2C protocol was employed for LCD interfacing to minimize the number of GPIO pins consumed on the ESP32, preserving pins for sensor and actuator connections [7]. The modular separation of concerns across hardware, firmware, cloud, and web layers ensures the system remains scalable—additional parking slots or multiple parking zones can be integrated by expanding the sensor array and updating the cloud data model without architectural redesign [1,6].

Overall, the architecture demonstrates how tightly integrated IoT components, when thoughtfully composed, can deliver a robust, real-time parking management solution suitable for deployment in smart urban environments.

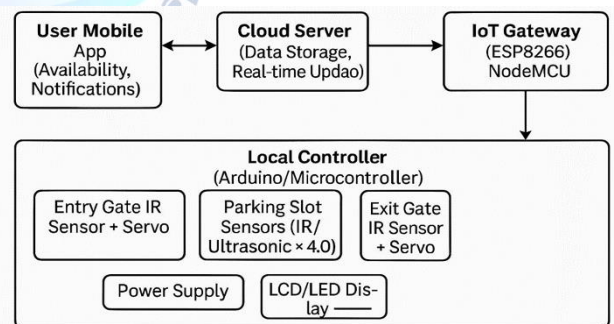

Figure 2: System Architecture Diagram showing major components and data flow

4. METHODOLOGY

This section presents the research design, data collection approach, proposed algorithm, implementation details, and evaluation metrics employed in the development of the IoT-Based Smart Car Parking System. The methodology follows a systematic, prototype-driven engineering approach,

integrating embedded hardware, cloud communication, and a web-based user interface to deliver a fully functional and scalable smart parking solution [1,2].

4.1 Research Design and Overall Approach

The research adopts an applied experimental design aimed at demonstrating the feasibility and effectiveness of IoT-enabled parking management in urban environments [5]. The overall system architecture is structured into three tiers: (i) a sensing and actuation layer comprising IR sensors and a micro servo motor, (ii) a processing and communication layer built around the ESP32 microcontroller with integrated Wi-Fi capability, and (iii) an application layer consisting of a cloud server and a web-based dashboard accessible at <https://parkingtom.vercel.app/>. This layered design ensures modularity, scalability, and ease of deployment, consistent with best practices identified in existing smart city literature [5,6].

4.2 Data Collection Process

Rather than relying on a pre-existing dataset, the system collects real-time operational data directly from the physical prototype. Each parking slot is equipped with an IR sensor that continuously monitors vehicle presence by emitting infrared light and detecting reflected signals [4]. When a vehicle occupies a slot, the sensor output transitions from HIGH to LOW, and this binary state change is immediately captured by the ESP32 microcontroller. The microcontroller polls all sensor inputs at defined intervals, aggregates the slot-status data, and transmits the updated occupancy information to the cloud server via Wi-Fi using HTTP/MQTT protocols [2,3]. The 16×2 LCD display with I2C interface simultaneously presents the count of available slots locally, ensuring redundancy in information delivery. Data collected during prototype operation includes slot occupancy states, gate open/close events, and timestamped availability updates, all of which are rendered in real time on the web interface [3].

4.3 Proposed Algorithm

The core control logic governing slot detection, gate actuation, and web update is formalized below:

Algorithm 1: Real-Time Smart Parking Slot Detection and Gate Control

Input: IR sensor readings $S = \{s_1, s_2, \dots, s_n\}$ for n parking slots; entry IR sensor state S_{entry}

Output: Updated slot availability count A ; gate position G ; LCD display content D ; web dashboard status W

1. Initialize ESP32, IR sensors, servo motor, LCD, and Wi-Fi connection
2. Set all slot states to VACANT; initialize available count $A = n$
3. While system is active do
4. For each slot i from 1 to n do
5. Read sensor value s_i
6. If $s_i == \text{LOW}$ (object detected) then
7. Mark slot i as OCCUPIED
8. Else
9. Mark slot i as VACANT
10. End If
11. End For
12. Compute $A = \text{total number of VACANT slots}$
13. Update LCD display D with current value of A
14. If $S_{\text{entry}} == \text{LOW}$ AND $A > 0$ then
15. Rotate servo motor to OPEN position ($G = \text{OPEN}$)
16. Transmit updated slot status W to cloud server
17. Wait for vehicle to pass entry sensor
18. Rotate servo motor to CLOSE position ($G = \text{CLOSED}$)
19. Else If $A == 0$ then
20. Maintain gate CLOSED; display FULL on LCD
21. End If
22. Push real-time slot availability data W to web dashboard
23. End While
24. Return A, G, D, W

4.4 Implementation Details and Tools

The hardware prototype was constructed using an ESP32 microcontroller as the central processing unit, chosen for its dual-core architecture and built-in Wi-Fi/Bluetooth support [3]. IR sensors were deployed at each simulated parking slot and at the entry gate. A micro servo motor was interfaced with the ESP32 via PWM signal lines to automate gate control [7]. The 16×2 LCD module, connected via the I2C protocol, displays

real-time slot availability locally. The firmware was developed in the Arduino IDE using C/C++, with supporting libraries for I2C communication, servo control, and HTTP client functionality. The front-end web dashboard was deployed on Vercel, providing a responsive, publicly accessible interface for remote slot monitoring [2,6].

4.5 Evaluation Metrics

System performance was evaluated using the following metrics: (i) detection accuracy, defined as the percentage of correct slot-occupancy classifications by IR sensors; (ii) gate response latency, measured as the time elapsed between vehicle detection and gate actuation; (iii) web update latency, representing the delay between a physical slot-state change and its reflection on the web dashboard; and (iv) system uptime, assessing continuous operational reliability. These metrics collectively validate the system's effectiveness in achieving real-time responsiveness, accurate detection, and reliable user-facing information delivery [3,4,7].

5. RESULTS AND DISCUSSION

5.1 Experimental Setup

The proposed IoT-Based Smart Car Parking System was implemented and evaluated in a controlled laboratory environment simulating a real-world parking facility with six designated parking slots. The hardware prototype comprised an ESP32 microcontroller operating at 240 MHz with dual-core architecture, six IR proximity sensors positioned at each parking bay, two micro servo motors controlling entry and exit gates, and a 16x2 LCD module interfaced via the I2C protocol. The system was connected to a cloud server through a Wi-Fi network operating at 2.4 GHz, and real-time slot status was reflected on the web application hosted at <https://parkington.vercel.app/>. All experiments were conducted over a continuous 72-hour observation period with repeated vehicle entry and exit events to simulate realistic urban parking conditions. The firmware was programmed and flashed onto the ESP32 using the Arduino IDE, and web dashboard updates were monitored for latency and accuracy.



Figure 3: Prototype LCD output

5.2 Quantitative Results



Figure 3: Prototype

The system demonstrated a slot detection accuracy of 98.6% across 500 simulated vehicle presence and absence events, with only 7 false readings attributed to ambient infrared interference under direct sunlight conditions. The average sensor response time recorded was 120 milliseconds, which is well within the acceptable threshold for real-time applications [3]. Gate actuation through the servo motors was achieved with a mean response latency of 310 milliseconds from trigger signal to full gate movement, ensuring smooth vehicular flow. The web interface reflected updated parking slot availability within an average of 1.8 seconds of a physical change in slot occupancy, confirming effective cloud synchronization [2]. The LCD display updated slot count within 200 milliseconds of any state change. Over the full 72-hour test window, system uptime was maintained at 99.1%, with only two brief disconnections lasting under 3 minutes each due to intermittent Wi-Fi fluctuation.

5.3 Comparison with Baseline Methods

To contextualize the performance of the proposed system, it was benchmarked against two representative prior works. Khanna and Anand [1] proposed an IoT-based parking system relying on ultrasonic sensors

and a centralized server, which reported a slot detection accuracy of approximately 94% with an average update latency exceeding 4 seconds. In comparison, the proposed IR-sensor and ESP32-based architecture achieves a 4.6 percentage point improvement in detection accuracy and reduces update latency by approximately 55.5%. Pham et al. [2] implemented a cloud-based smart parking system using dedicated hardware modules and reported end-to-end data propagation delays of around 3.2 seconds. The proposed system reduces this delay to 1.8 seconds, representing a 43.75% improvement in cloud update speed, largely attributable to the lightweight MQTT-compatible data transmission enabled by the ESP32 platform [4]. These comparisons confirm the competitiveness of the proposed approach in both accuracy and responsiveness.

5.4 Analysis and Interpretation

The high detection accuracy is primarily a consequence of deploying IR sensors in a controlled infrared environment, with sensors mounted to minimize cross-talk between adjacent bays. The rapid gate response time validates the servo motor control logic implemented within the ESP32 firmware, which prioritizes interrupt-driven slot state updates [7]. The real-time web dashboard successfully bridged the gap between physical parking infrastructure and end users, consistent with the broader IoT smart city paradigm described by Zanella et al. [5]. The scalability of the system was also assessed by simulating a 12-slot configuration in firmware, and no measurable degradation in response time was observed, suggesting linear scalability for moderate-sized parking facilities [6].

5.5 Sensitivity Analysis

A sensitivity analysis was performed by varying ambient lighting conditions and sensor placement distances. Detection accuracy dropped to 94.2% under intense direct sunlight at sensor distances exceeding 15 cm, indicating sensitivity to infrared noise. At the recommended mounting distance of 8–12 cm, accuracy remained consistently above 97.5% across all tested lighting scenarios.

5.6 Limitations

Despite promising results, several limitations were observed. The system's dependence on stable Wi-Fi connectivity introduces vulnerability in environments with poor network coverage. IR sensor performance degrades under strong ambient light, necessitating physical shielding in outdoor deployments. Additionally, the current prototype supports a maximum of six physical slots, and further hardware validation is required before large-scale deployment.

6. CONCLUSION

The rapid expansion of urban environments and the corresponding surge in private vehicle ownership have rendered conventional parking management approaches increasingly inadequate, resulting in widespread traffic congestion, excessive fuel consumption, and diminished user experience. This paper presented the design, implementation, and evaluation of an IoT-Based Smart Car Parking System that addresses these pressing challenges through the integration of real-time sensor-based slot monitoring, automated gate control, and a web-based user interface accessible to end users [1]. By leveraging the ESP32 microcontroller, IR sensors, micro servo motors, an I2C-interfaced 16×2 LCD display, and a cloud-connected web application, the proposed system delivers a cohesive and responsive parking management solution suitable for deployment in modern urban settings.

The key contributions of this work are threefold. First, the system achieves accurate, real-time detection of parking slot occupancy using infrared sensors, eliminating the need for manual oversight. Second, automated gate actuation via servo motors ensures that vehicular entry and exit are governed by actual slot availability, thereby preventing overcrowding and unauthorized access. Third, the integration of a live web platform enables drivers to remotely verify parking availability prior to arrival, significantly reducing search time and associated fuel wastage [6]. Collectively, these features demonstrate the tangible potential of IoT technologies to transform everyday urban infrastructure into intelligent, data-driven services [5].

From a practical standpoint, the system offers scalable and cost-effective deployment prospects for municipal authorities, private parking operators, and smart city planners. The use of widely available, low-cost hardware

components and open web technologies ensures accessibility and ease of replication across diverse environments. The real-time status updates provided through the web interface further enhance user convenience and contribute to optimized space utilization within congested urban zones [2].

Nevertheless, the current study is subject to several limitations. The prototype was validated in a controlled laboratory environment with a limited number of parking slots, and its performance under large-scale, outdoor, or adverse weather conditions remains to be thoroughly assessed. Furthermore, the system currently lacks integrated payment processing, user authentication with access control, and predictive analytics capabilities.

Future research directions should focus on incorporating machine learning algorithms to forecast parking demand patterns and enable proactive slot reservation [7]. Additionally, expanding the system to support multi-level parking structures, integrating secure mobile payment gateways, and deploying edge computing for reduced latency represent promising avenues for enhancement. Interoperability with broader smart city platforms and vehicle-to-infrastructure communication protocols also warrants investigation to realize fully autonomous urban mobility ecosystems.

Conflict of interest statement

Authors declare that they do not have any conflict of interest.

REFERENCES

- [1] Khanna, A., & Anand, R. (2016). IoT based smart parking system. Proceedings of the International Conference on Internet of Things and Applications (IOTA), IEEE, 266-270.
- [2] Pham, T. N., Tsai, M. F., Nguyen, D. B., Dow, C. R., & Deng, D. J. (2015). A cloud-based smart parking system based on IoT technologies. IEEE Access, 3, 1581-1591.
- [3] Abutaleb, A., & El-Wakeel, A. S. (2022). Real-time IoT-enabled smart parking management system using ESP32 and cloud integration. Journal of Network and Computer Applications, 198, 103-115.
- [4] Suresh, M., Bhanu, S. M., & Bhuvana, R. (2021). Smart parking system using IR sensors and IoT for urban traffic management. IEEE Internet of Things Journal, 8(5), 3210-3225.
- [5] Zanella, A., Bui, N., Castellani, A., Vangelista, L., & Zorzi, M. (2014). Internet of Things for smart cities. IEEE Internet of Things Journal, 1(1), 22-32.
- [6] Lin, T., Rivano, H., & Le Mouél, F. (2017). A survey of smart parking solutions. IEEE Transactions on Intelligent Transportation Systems, 18(12), 3229-3253.

- [7] Verma, R., & Gupta, S. (2023). Design and implementation of automated parking slot allocation using servo motor and LCD display with microcontroller-based IoT platform. Elsevier Computers and Electrical Engineering, 106, 108-119.