

A Resonant Converter with LLC for DC-to-DC Converter Based Applications

M. Radha

PG Scholar, Department of EEE
Anurag Engineering College, Kodad.

J. Srinivasa Rao

Associate Professor, Department of EEE
Anurag Engineering College, Kodad.

Abstract - Conventional voltage mode control only offers limited performance for LLC series resonant DC-to-DC converters experiencing wide variations in operational conditions. When the existing voltage mode control is employed, the closed-loop performance of the converter is directly affected by unavoidable changes in power stage dynamics. Thus, a specific control design optimized at one particular operating point could become unacceptable when the operational condition is varied. This paper presents a new current mode control scheme which could consistently provide good closed-loop performance for LLC resonant converters for the entire operational range. The proposed control scheme employs an additional feedback from the current of the resonant tank network to overcome the limitation of the existing voltage mode control. The superiority of the proposed current mode control over the conventional voltage mode control is verified using an experimental 150 W LLC series resonant DC-to-DC converter.

Keywords: LLC series resonant DC-to-DC converters; current mode control; closed-loop performance; voltage mode control

I. INTRODUCTION

With the depletion of fossil fuel reserves and the increase in greenhouse gas emissions, the research and development of plug-in hybrid electric vehicles (PHEVs) and pure electric vehicles (EVs) have been carried intensively. In today's PHEVs and EVs, an on-board charger is installed to charge the high-power lithium-ion battery pack through the utility power. According to a thorough survey, the most common EV/PHEV charger architecture consists of a boost-type ac-dc converter for active power factor correction (PFC) and an isolated dc-dc converter as the second stage as shown in Fig. 1. The characteristic of this type of charger is mainly dependent on the dc-dc stage since the output voltage and current are regulated in this stage. Therefore, an efficient and compact isolated dc-dc converter is one of the most important topics for EV and PHEV battery charger. The LLC resonant converter with soft switching capability for a wide operating range is considered to be a favourable topology to achieve both high efficiency and high-power density.

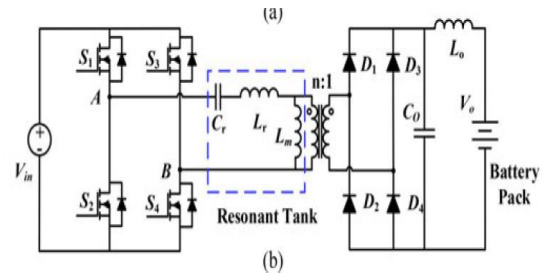

FIG 1 LLC RESONANT CONVERTER

A typical schematic of a full-bridge LLC resonant dc-dc converter used in EV/PHEV charger. The resonant tank consists of three reactive components: L_r and C_r in series, and L_m in parallel with the primary of an $n:1$ ideal transformer. C_r denotes the resonant capacitor, L_m is the magnetizing inductance, and L_r is the leakage inductance reflected in the primary side. The LLC converter modifies the gain characteristics of a series resonant converter (SRC) by utilizing the transformer magnetizing inductance to form multiple resonant stages. It greatly improves the light-load efficiency and allows the boost mode operation. However, its multiple resonant stages and various operation modes make it difficult to design.

Resonant converters have been used in many applications, including induction heating, and fuel cells. However, the wide output voltage range requirements for a battery charger are drastically different and challenging compared to telecom applications, which operate in a narrow output voltage range. It has four distinct operating modes: bulk, absorption, equalization, and maintenance. In the bulk mode, the charger limits the maximum charging current to a preset I_{MAX} value while monitoring the battery voltage. In the absorption mode, the charger elevates the voltage to VABS while monitoring the current. This voltage is just below the battery gassing voltage. When it has reached this point, the battery is between 70% and 90% state of charge (SOC). When the current decreases to a preset value, I_{OCT} , the charger enters the equalization mode. When it has reached this point, the battery is at 100% SOC. Equalizing is an overcharge performed on lead acid batteries after they have been fully charged.

In the previous literatures, the load is usually assumed to be a pure constant resistor and the output is usually fixed. The wide voltage gain range is normally required to resist the input variation or to meet the holdup time. However, the design requirements of an LLC converter for a high voltage lithium-ion battery charger can be distinguished from the aforesaid applications. First of all, the non-linear load i-v characteristics related to the charging profile exist in the design of a resonant converter for battery charger applications. Second, not only the voltage ripple coming from the front-end stage needs to be resisted, but the output voltage also varies significantly in the whole charging process. In addition, the LLC converter should be able to handle a wide adjustable regulated output voltage range even when the load current varies. Third, the charge process for a lithium-ion battery usually contains several stages, and the output voltage and the load power change significantly during the whole charging process.

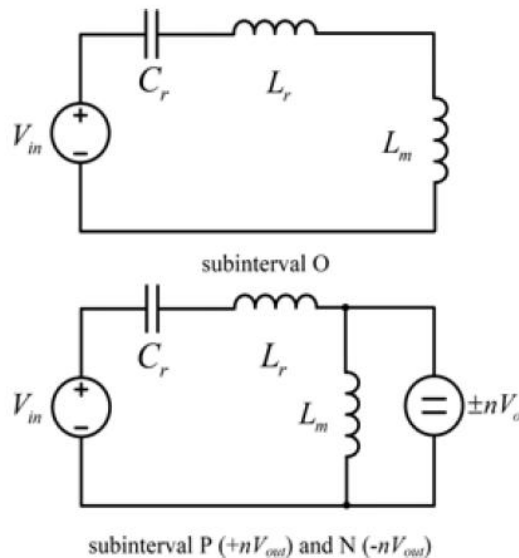

FIG. 2 INTERVALS OF THE LLC CONVERTER.

It may go through different combination of no-load, full-load, and light-load conditions according to the control of the battery management system. Hence, high efficiency should be maintained in different load conditions. As a result, it is inappropriate to pick just one load condition out of the whole charging process to be the nominal condition to be targeted, which is normally done in the resistive load applications. The whole operating trajectory has to be taken into account for an optimal design.

II. LLC RESONANT CONVERTER

The basic concept of current mode control is to employ an additional feedback from the tank circuit variable to construct the composite feedback signal that would not be

affected by potential changes in power stage dynamics. This aim can be accomplished by adapting the two-loop control scheme. When one tank circuit variable is applied as the inner feedback signal and subsequently mixed with the outer voltage feedback signal, the composite feedback signal will be generated, which will largely remain unaffected by potential drifts in power stage dynamics. The theoretical validation of this statement will be given later in this section.

Because the switching action exists in both the input switches and the output rectifier bridge, the LLC resonant converter represents a nonlinear and time-variant system, which makes the analysis complicated. However, by dividing the circuit operation into different subintervals, the converter can be described between transitions. From symmetrical condition of the resonant converter, the steady-state can be characterized by a half period of operation. During the positive half switching cycle in which S1, S2 are turned ON.

The capital letters O, P, and N are used to denote the three different subintervals, which is characterized by the voltage polarity (off, positive, and negative) across the magnetizing inductor L_m . The parameter n is the transformer turns ratio. The subinterval O happens when the output is blocked by the diode rectifier, which forces the magnetizing inductor L_m to participate in the series tank's resonance.

According to analysis and simulation, a total of nine operation modes can be found by combining the intervals in different sequences. The operation modes can be named by the appearance order in which the subintervals occur in a half period. For instance, PO mode means that the subinterval P maintains for $\theta \in [0, \alpha)$ and it is followed by subinterval O for the rest of the half cycle ($\theta \in [\alpha, \gamma)$). It can be seen that the main power interval P occurs in every half period except for the O mode under zero-load condition. So O mode is regarded as the cut-off mode since no power is delivered to the output. There are six major operation modes (PN, PON, PO, OPO, NP, and NOP) that can be observed above the second resonant frequency when the operating frequency and load condition varies. which are P mode at resonant frequency and the OP mode at the boundary between NOP and OPO mode.

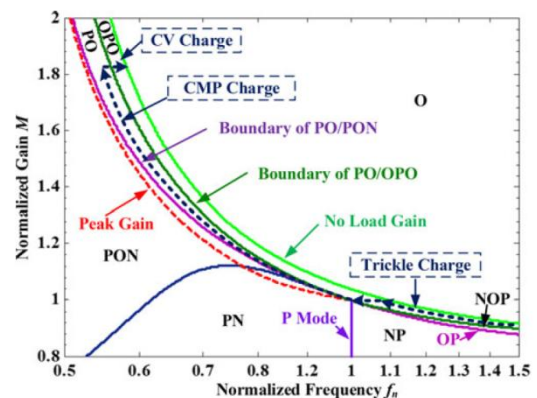

Fig. 3 Gain–frequency mode boundaries of LLC resonant

As shown in Fig. 3, the distribution of the operation modes in a range of switching frequency and gain is mainly determined by parameter l , the LLC resonant converter can be described and solved precisely as long as the operation conditions are known. The characteristics and distribution of operation mode provide importance design guideline for different applications.

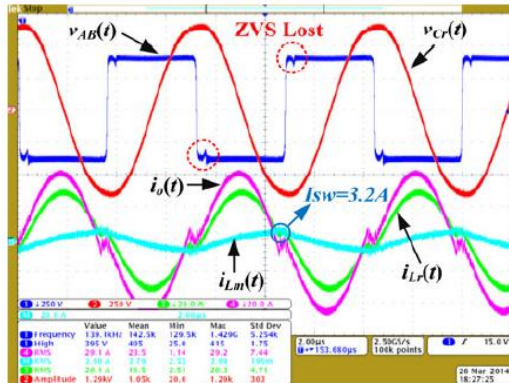

FIG 4 EXPERIMENTAL WAVEFORMS OF LLC CONVERTER

The experimental waveforms are shown in Fig. 4. In this figure, $v_{AB}(t)$ denotes the voltage applied on the resonant tank. The voltage across the resonant capacitor is shown as $v_{Cr}(t)$. $i_{Lr}(t)$, and $i_{Lm}(t)$ are used to indicate the primary resonant tank current and the transformer magnetizing current respectively. The secondary current through the rectifier is indicated as $i_o(t)$.

CONCLUSION

This paper proposed a new current mode control scheme for LLC series resonant DC-to-DC converters. Using the additional feedback from the resonant tank current, the proposed control scheme effectively nullifies the consequential effects of possible changes in power stage dynamics. The mode boundaries and distribution of LLC converter are discussed in the need of locating the operation trace to the preferable region. The key parameters that affect the designed operating trajectory are identified. Finally, all the discussion has led to a design procedure that ensures soft switching under all operating conditions. A 6.6 kW, 390 V dc input and 250–450 V output LLC converter is built using the proposed method, which achieves 97.96% peak efficiency. The future research will be focused on the power density improvement by optimal transformer design and a straightforward design procedure without recursive loops.

REFERENCES

- [1] D.W. Gao, C. Mi, and A. Emadi, "Modeling and simulation of electric and hybrid vehicles," *Proc. IEEE*, vol. 95, no. 4, pp. 729–745, Apr. 2007.
- [2] A. Emadi, S. Williamson, and A. Khaligh, "Power electronics intensive solutions for advanced electric, hybrid electric, and fuel cell vehicular power systems," *IEEE Trans. Power Electron.*, vol. 21, no. 3, pp. 567–577, May 2006.
- [3] A. M. Rahimi, "A lithium-ion battery charger for charging up to eight cells," in *Proc. IEEE Conf. Vehicle Power Propulsion*, 2005, pp. 131–136.
- [4] B. Singh, B. N. Singh, A. Chandra, K. Al-Haddad, A. Pandey, and D. P. Kothari, "A review of single-phase improved power quality ACDC converters," *IEEE Trans. Ind. Electron.*, vol. 50, no. 5, pp. 962–981, Oct. 2003.
- [5] L. Petersen and M. Andersen, "Two-stage power factor corrected power supplies: The lowcomponent-stress approach," in *Proc. IEEE Appl. Power Electron. Conf. Expo.*, 2002, vol. 2, pp. 1195–1201.
- [6] B. Lu, W. Dong, S. Wang, and F. C. Lee, "High frequency investigation of single-switch CCM power factor correction converter," in *Proc. IEEE Appl. Power Electron. Conf. Expo.*, 2004, vol. 3, pp. 1481–1487.
- [7] L. Yang, B. Lu, W. Dong, Z. Lu, M. Xu, F. C. Lee, and W. G. Odendaal, "Modeling and characterization of a 1KW CCM PFC converter for conducted EMI prediction," in *Proc. IEEE Appl. Power Electron. Conf. Expo.*, 2004, vol. 2, pp. 763–769.
- [8] A. K. S. Bhat, "Analysis and design of LCL-type series resonant converter," *IEEE Trans. Ind. Electron.*, vol. 41, no. 1, pp. 118–124, Feb.1994.