



# Filter Based Solar Power Generation System with a Seven Level Inverter

K N V Rajesh<sup>1</sup> | S. Rajasekhar<sup>2</sup>

<sup>1</sup>PG Scholar, Department of EEE, ASR College of Engineering and Technology, JNTUK, Andhra Pradesh.

<sup>2</sup>Assistant Professor, Department of EEE, ASR College of Engineering and Technology, JNTUK, Andhra Pradesh

## ABSTRACT

*This paper proposes a new solar power generation system, which is composed of a DC/DC power converter and a new seven-level inverter. The DC/DC power converter integrates a DC-DC boost converter and a transformer to convert the output voltage of the solar cell array into two independent voltage sources with multiple relationships. This new seven-level inverter is configured using a capacitor selection circuit and a full-bridge power converter, connected in cascade. The capacitor selection circuit converts the two output voltage sources of DC-DC power converter into a three-level DC voltage and the full-bridge power converter further converts this three-level DC voltage into a seven-level AC voltage. In this way, the proposed solar power generation system generates a sinusoidal output current that is in phase with the utility voltage and is fed into the utility. The salient features of the proposed seven-level inverter are that only six power electronic switches are used and only one power electronic switch is switched at high frequency at any time. A prototype is developed and tested to verify the performance of this proposed solar power generation system.*

**KEYWORDS:** Multilevel Inverter, grid-connected, pulse width modulated (PWM) inverter

*Copyright © 2015 International Journal for Modern Trends in Science and Technology  
All rights reserved.*

## I. INTRODUCTION

The extensive use of fossil fuels has resulted in the global problem of greenhouse emissions. Moreover, as the supplies of fossil fuels are depleted in the future, they will become increasingly expensive. Thus solar energy is becoming more important since it produces less pollution and the cost of fossil fuel energy is rising, while the cost of solar arrays is decreasing. In particular, small-capacity distributed power generation systems using solar energy may be widely used in residential applications in the near future.

The power conversion interface is important to grid-connected solar power generation systems because it converts the DC power generated by a solar cell array into AC power and feeds this AC power into the utility grid. An inverter is necessary in the power conversion interface to convert the DC power to AC power [2-4]. Since the output voltage of a solar cell array is low, a DC-DC power converter is used in a small-capacity solar power

generation system to boost the output voltage so it can match the DC bus voltage of the inverter.

## II. EXISTING SYSTEM

The power conversion efficiency of the power generation system. The proposed solar power generation system is composed of a solar cell array, a DC-DC power converter and a new seven-level inverter. The solar cell array is connected to the DC-DC power converter, and the DC-DC power converter is a boost converter that incorporates a transformer with a turn ratio of 2:1. The DC-DC power converter converts the output power of the solar cell array into two independent voltage sources with multiple relationships, which supply the seven-level inverter. This new seven-level inverter is composed of a capacitor selection circuit and a full-bridge power converter, connected in cascade. The power electronic switches of capacitor selection circuit determine the discharge of the two capacitors while the two capacitors are being discharged individually or in series. Because of the multiple relationships

between the voltages of the DC capacitors, the capacitor selection circuit outputs a three-level DC voltage. The full-bridge power converter further converts this three-level DC voltage to a seven-level AC voltage that is synchronized with the utility voltage. In this way, the proposed solar power generation system.

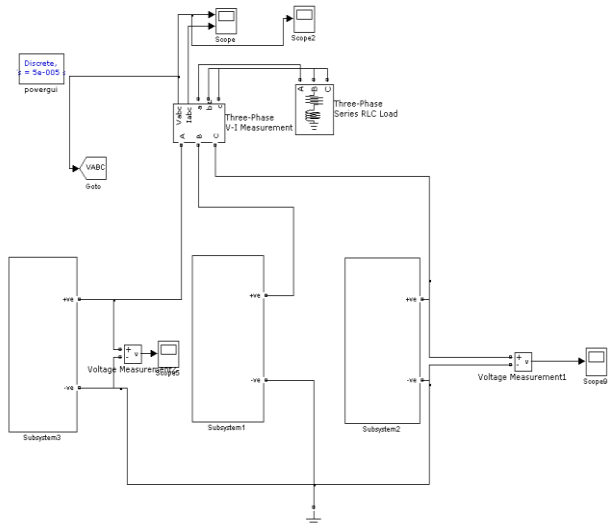

Figure 1: Matlab simulink main diagram

### III. PROPOSED SYSTEM

As seen in Fig. 1, the DC-DC power converter incorporates a boost converter and a current-fed forward converter. The boost converter is composed of an inductor, LD, a power electronic switch, SD1, and a diode, DD3. The boost converter charges capacitor C2 of the seven-level inverter. The current-fed forward converter is composed of an inductor, LD, power electronic switches, SD1 and SD2, a transformer and diodes, DD and DD2. The current-fed forward converter charges capacitor C1 of the seven-level inverter. The inductor, LD, and the power electronic switch, SD1, of the current-fed forward converter are also used in the boost converter.

Figure 1 shows the operating circuit of the DC-DC power converter when SD1 is turned on. The solar cell array supplies energy to the inductor LD. When SD1 is turned off and SD2 is turned on, its operating circuit is shown in Fig.1. Accordingly, capacitor C1 is connected to capacitor C2 in parallel through the transformer, so the energy of inductor LD and the solar cell array charge capacitor C2 through DD3 and charge capacitor C1 through the transformer and DD1 during the off-state of SD1. Since capacitors C1 and C2 are charged in parallel by using the transformer, the voltage ratio of

capacitors C1 and C2 is the same as the turn ratio (2:1) of the transformer.

### Securely determining own location.

In mobile environments, self-localization is mainly achieved through Global Navigation Satellite Systems, e.g., GPS, whose security can be provided by cryptographic and noncryptographic defense mechanisms. Alternatively, terrestrial special purpose infrastructure could be used along with techniques to deal with non honest beacons. We remark that this problem is orthogonal to the problem of NPV. In the rest of this paper, we will assume that devices employ one of the techniques above to securely determine their own position and time reference.

### IV. SEVEN LEVEL INVERTER

As seen in Fig. 1, the seven-level inverter is composed of a capacitor selection circuit and a full-bridge power converter, which are connected in cascade. Operation of the seven-level inverter can be divided into the positive half cycle and the negative half cycle of the utility. For ease of analysis, the power electronic switches and diodes are assumed to be ideal, while the voltages of both capacitors C1 and C2 in the capacitor selection circuit are constant and equal to  $V_{dc}/3$  and  $2V_{dc}/3$ , respectively.

Since the output current of the solar power generation system will be controlled to be sinusoidal and in phase with the utility voltage, the output current of the seven-level inverter is also positive in the positive half cycle of the utility. The operation of the seven-level inverter in the positive half cycle of the utility can be further divided into four modes, as shown in Fig.3.

### V. EXPERIMENTAL RESULTS

To verify the performance of the proposed solar power generation system, a prototype was developed with a controller based on the DSP chip TMS320F28035. The power rating of the prototype is 500W, and the prototype was used for a single-phase utility with 110V and 60Hz. Table II shows the main parameters of the prototype.



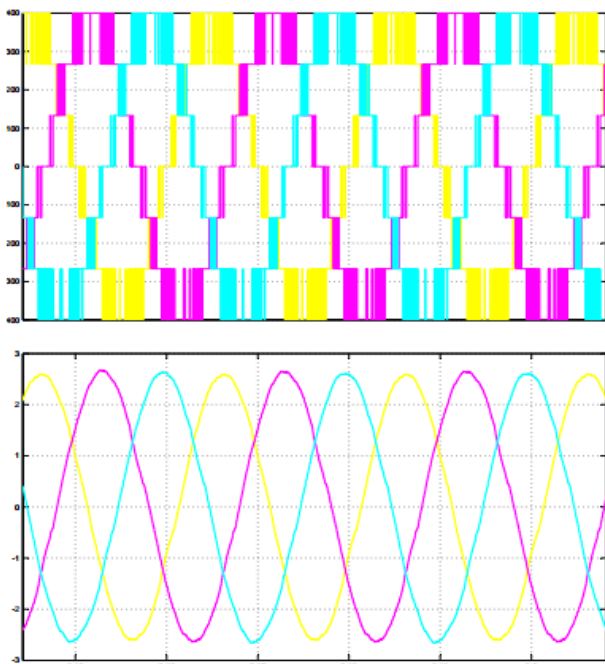

Figure 2: Voltage and current waveforms without LC filter

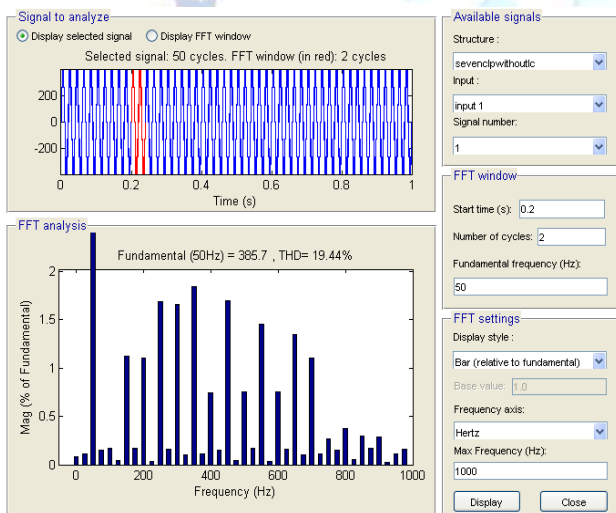

Figure 3: THD analysis 19.44% without LC filter

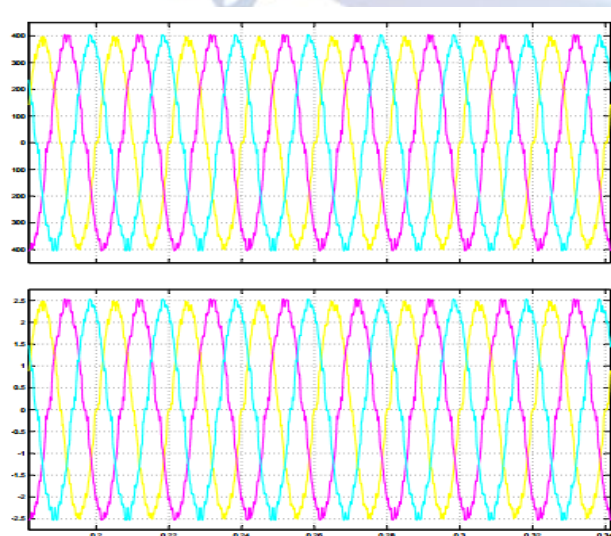

Figure 4: Voltage and current waveform using LC filter

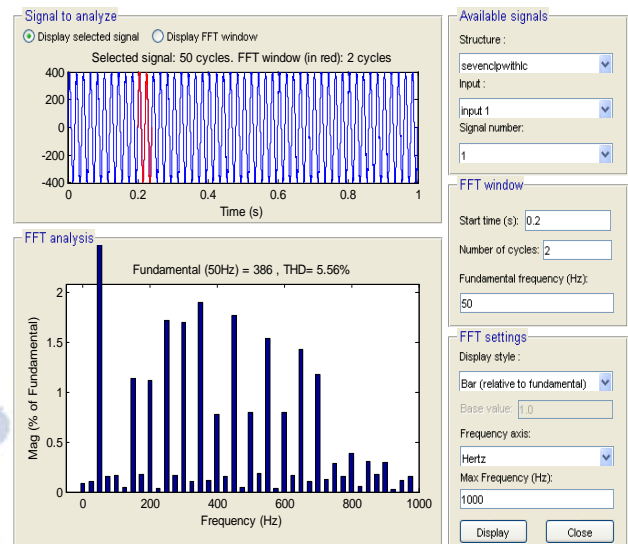

Figure 5: THD analysis 5.56% with LC filter

## VI. CONCLUSION

This paper proposes a solar power generation system to convert the DC energy generated by a solar cell array into AC energy that is fed into the utility. The proposed solar power generation system is composed of a DC/DC power converter and a seven-level inverter. The seven-level inverter contains only six power electronic switches, which simplifies the circuit configuration. Furthermore, only one power electronic switch is switched at high frequency at any time to generate the seven-level output voltage. This reduces the switching power loss and improves the power efficiency. The voltages of the two DC capacitors in the proposed sevenlevel inverter are balanced automatically, so the control circuit is simplified. Experimental results show that the proposed solar power generation system generates a sevenlevel output voltage and outputs a sinusoidal current that is in phase with the utility voltage, yielding a power factor of unity. In addition, the proposed solar power generation system can effectively trace the maximum power of solar cell array

conclusion section is not required. Although a conclusion may review the main points of the paper, do not replicate the abstract as the conclusion. A conclusion might elaborate on the importance of the work or suggest applications and extensions.

## REFERENCES

- [1] R.A. Mastromauro, M. Liserre, A.Dell'Aquila, "Control Issues in Single-Stage Photovoltaic Systems: MPPT, Current and Voltage Control," IEEE Trans Ind. Informat., Vol. 8, No.2, pp.241-254, 2012.

- [2] Z. Zhao, M. Xu, Q. Chen, J.S Jason Lai, Y. H. Cho, "Derivation, Analysis, and Implementation of a Boost-Buck Converter-Based High-Efficiency PV Inverter," *IEEE Trans. Power Electron.*, Vol. 27, No. 3, pp.1304-1313, 2012.
- [3] M. Hanif, M. Basu, K. Gaughan., "Understanding the operation of a Z-source inverter for photovoltaic application with a design example," *IET Power Electron.*, Vol. 4, No. 3, pp.278-287, 2011.
- [4] J. M. Shen, H. L. Jou, J. C. Wu, "Novel Transformer-less Grid-connected Power Converter with Negative Grounding for Photovoltaic Generation System," *IEEE Trans. Power Electronics*, Vol. 27, No. 4, pp.1818-1829, 2012.
- [5] N. Mohan, T. M. Undeland, W. P. Robbins, *Power Electronics Converters, Applications and Design*, Media Enhanced 3rd ed. New York: John Wiley & Sons, 2003.
- [6] K. Hasegawa, H. Akagi, "Low-Modulation-Index Operation of a Five-Level Diode-Clamped PWM Inverter With a DC-Voltage-Balancing Circuit for a Motor Drive," *IEEE Trans. Power Electron.*, Vol. 27, No. 8, pp.3495-3505, 2012.
- [7] E. Pouresmaeil, D. Montesinos-Miracle, O. Gomis-Bellmunt, "Control Scheme of Three-Level NPC Inverter for Integration of Renewable Energy Resources Into AC Grid," *Syst. J.*, Vol.6, No.2, pp.242-253, 2012.
- [8] S. Srikanthan, M. K. Mishra, "DC Capacitor Voltage Equalization in Neutral Clamped Inverters for DSTATCOM Application," *IEEE Trans. Ind. Electron.* Vol. 57, No.8, pp.2768-2775, 2010.
- [9] M. Chaves, E. Margato, J. F. Silva, S. F. Pinto, "New approach in back-to-back m-level diodeclamped multilevel converter modelling and direct current bus voltages balancing," *IET Power Electron.*, Vol. 3, No. 4, pp. 578-589, 2010.
- [10] J. D. Barros, J. F. A. Silva, E. G. A Jesus, "Fast-Predictive Optimal Control of NPC Multilevel Converters," *IEEE Trans. Ind. Electron.*, Vol.60, No.2, pp.619-627, 2013.
- [11] A.K. Sadigh, S. H. Hosseini, M. Sabahi, G. B. Gharehpetian, "Double Flying Capacitor Multicell Converter Based on Modified Phase-Shifted Pulsewidth Modulation," *IEEE Trans. Power Electron.*, Vol. 25, No.6, pp. 1517-1526, 2010.
- [12] S. Thielemans, A. Ruderman, B. Reznikov, J. Melkebeek, "Improved Natural Balancing With Modified Phase-Shifted PWM for Single-Leg Five-Level Flying-Capacitor Converters," *IEEE Trans. Power Electron.*, Vol. 27, No. 4, pp. 1658-1667, 2012.
- [13] S. Choi, M. Saeedifard, "Capacitor Voltage Balancing of Flying Capacitor Multilevel Converters by Space Vector PWM," *IEEE Trans. Power Del.*, Vol.27, No.3, pp.1154-1161, 2012.
- [14] L. Maharjan, T. Yamagishi, H. Akagi, "Active-Power Control of Individual Converter Cells for a Battery Energy Storage System Based on a Multilevel Cascade PWM Converter," *IEEE Trans. Power Electron.*, Vol. 27, No.3, pp.1099-1107, 2012.
- [15] X. She, A. Q. Huang, T. Zhao; G. Wang, "Coupling Effect Reduction of a Voltage-Balancing Controller in Single-Phase Cascaded Multilevel Converters,".